

## Preface

Thank you for purchasing the JT580 series inverter developed by Wuxi Juditech Electric Co., Ltd.

The JT580 series inverter is a general-purpose high-performance current vector control inverter. It can implement the control of asynchronous motor. It is used to drive various automation production equipment involving textile, paper-making, wire drawing, machine tool, packing, food, fan and pump.

This manual describes the correct use of the JT580 series inverter, including selection, parameter setting, commissioning, maintenance & inspection. Read and understand the manual before use and forward the manual to the end user.

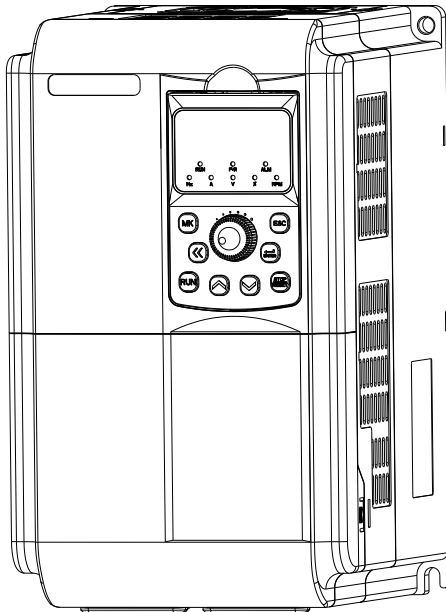

**Note**

- The drawings presented in this instructions are sometimes shown without covers or protective guards. Always replace the equipment's cover or protective guard as specified first, and then operate the products in accordance with the instructions.
  
- The drawings in the manual are shown for description only and may not match the product you purchased.
  
- The instructions are subject to change, without notice ,due to product upgrade, specification modification as well as efforts to increase the accuracy and convenience of the manual.
  
- Conduct our agents or customer service center if you have problems during the use.

Service Hotline: 0510-85380261

Fax: 0510-85380361

24-hour technical service line:86 13306170378 and 86 13306170877

# Contents

<b>Preface .....</b>	<b>1</b>
<b>Contents.....</b>	<b>3</b>
<b>Chapter 1 Safety Information and Precautions .....</b>	<b>5</b>
1.1 Security Information.....	5
<b>Chapter 2 Product Information .....</b>	<b>8</b>
2.1 Designation Rules .....	8
2.2 Nameplate .....	8
2.3 JT580 Models and Technical Data .....	8
2.4 Product Description of Each Part .....	9
2.5 Technical Specifications.....	10
2.6 Appearance and Installation Size of the Keyboard .....	14
2.7 Appearance and Hole Size of the Keyboard Tray .....	15
<b>Chapter 3 Mechanical Installation .....</b>	<b>15</b>
3.1 Installation Environment .....	15
3.2 The Disassembly of The Cover Plate .....	17
<b>Chapter 4 Electrical Installation.....</b>	<b>18</b>
4.1 Electrical Installation .....	18
4.2 Description of Peripheral Electrical Devices .....	19
4.3 Peripheral Electrical Components Selection Guidance .....	19
4.4 Selection of Braking Unit and Braking Resistor .....	20
4.5 Wiring Method.....	22
<b>Chapter 5 Operating and Display .....</b>	<b>28</b>
5.1 Operation and Display Interface.....	28
5.2 Function Indicator Description.....	28
5.3 Keyboard Button Description Table .....	28
5.4 Viewing and Modifying Function Codes .....	29
5.5 Selecting Menu Mode.....	30
<b>Chapter6 Function Parameter List .....</b>	<b>31</b>
<b>Chapter7 Description of Function Codes .....</b>	<b>66</b>
Group F0 :Basic Parameters .....	66
Group F1: Motor parameters .....	71
Group F2:Input Terminal .....	73
Group F3: Output Terminals .....	80
Group F4: Auxilliary Functions .....	84
Group F5: Vector Control Parameters.....	92
Group F6: V/F Control Parameters .....	95
Group F7: Start/Stop Control .....	97
Group F8: Operation Panel and Display .....	101

Group F9: Fault and Protection .....	103
Group FA: Process Control PID Function .....	109
Group FB: Swing Frequency, Fixed Length ,Count and Torque Control Parameters.....	112
Group FC: Multi-Reference and Simple PLC Function Parameters .....	116
Group FD: User-defined Parameters .....	118
Group FE:Quick Menu Parameters .....	118
Group P0:Analog Four Points Offset Parameters .....	119
Group P1:Analog Calibration Parameters.....	121
Group H0: Monitoring Parameters .....	122
<b>Chapter 8 Maintenance and Troubleshooting.....</b>	<b>125</b>
8.1 Routine Repair and Maintenance of the JT580 .....	125
8.2 Warranty Agreement.....	125
8.3 Faults and Solutions .....	126
8.4 Common Faults and Solutions .....	130

## Chapter 1 Safety Information and Precautions

In this manual, Safety cautions are divided into two types:

 **DANGER:** indicates that failure to comply with the notice will result in severe personal injury or even death.

 **WARNING:** indicates that failure to comply with the notice will result in personal injury or property damage.

Read this chapter carefully so that you have a thorough understanding, and perform all operations such as installation, commissioning or maintenance by following the notices in this chapter. Juditech will assume no liability or responsibility for any injury or loss caused by improper operation.

### 1.1 Security Information

Before installation

 <b>Danger</b>
<ul style="list-style-type: none"><li>•The AC drive is designed to the speed control of asynchronous motor, any other uses may cause damage of the AC drive or result in a fire.</li><li>•The AC device shouldn't be applied simply in medical devices or other situations directly related to personal safety.</li></ul>

Checking

 <b>Warning</b>
<ul style="list-style-type: none"><li>• Do not install the AC device if you find component missing or damage upon unpacking.</li></ul>

During installation

 <b>Warning</b>
<ul style="list-style-type: none"><li>•Handle the AC device with care during transportation to prevent damage to the AC device.</li><li>•Install the AC device on incombustible objects such as metal, and keep it away from combustible materials. Failure to comply may result in a fire.</li><li>•Do not drop wire end or screw into the AC drive. Failure to comply will result in damage to the AC drive.</li><li>•If the AC device is installed in cabinet, fan and ventilation opening should be set for rejection of heat.</li></ul>

Wiring

 <b>Danger</b>
<ul style="list-style-type: none"><li>•Wiring must be performed only by qualified personnel under instructions described in this manual. Failure to comply may result in</li></ul>

unexpected accidents.

- Ensure that the power supply is cut off before wiring. Failure to comply may result in electric shock.
- Tie the AC drive to ground properly according to the requirements. Failure to comply may result in electric shock.
- Do not touch the terminals of the major loop, and make sure the major loop wires are not connect to the shell. Failure to comply may result in electric shock.
- The leakage current of the AC drive is greater than 5 mA and the specific value is determined by the working condition. The AC drive and motor must connect to the ground properly for safe.



#### Warning

- Never connect the power cables to the output terminals(U,V,W) of the AC drive. Failure to comply will result in damage to the AC drive.
- Never connect LC/RC noise filter for phase advance, like capacitance, to the output terminals. Failure to comply will result in damage to the AC drive.
- Ensure that the power phases and voltage are match the data on nameplate. Failure to comply may result in damage to the AC drive.
- The major loop and control loop should be wired separately or crossly. Failure to comply may result in disturb of the control signal.
- The cable for major loop should be shielded by insulating bush.
- Input or output reactor is recommended when the input or output cable is longer than 100 meters. Failure to comply may result in damage to the AC drive or the motor.

#### Running



#### Danger

- Cover the AC drive properly before power-on and never open the cover plate with power. Failure to comply may cause electric shock.
- Isolation measures should be adopted for machine with automatic reset of fault or start after the power failure. Failure to comply may result in personal injury.
- Never touch the terminals when the AC drive is on power, even it's on stop state. Failure to comply will result in electric shock.
- Never reset the alarm or warning before cutting off the running command. Failure to comply may result in personal injury.



#### Warning

- Do not start/stop the AC drive by turning the contactor ON/OFF. Failure to comply will result in damage to the AC drive.
- Ensure the motor and machine are in permitted useful range before running. Failure to comply will result in damage of machine.
- Do not touch the fan nor the discharging resistor, otherwise you may get burnt.
- Do configuring the mechanical lock device in using of elevator equipment.

- Do not change the default factory settings of the AC drive. Failure to comply will result in damage to the AC drive.
- Do setting the interlock with two contactors which are using in switching of VF/WF.

Maintenance

-  **Danger**
- Do not repair or maintain the AC drive at power-on. Failure to comply will result in electric shock.
  - Ensure power-off before removing the cover plate.
  - Repair or maintain the AC drive only ten minutes after the AC drive is powered off or the charging LED is off. Otherwise, the residual voltage in the capacitor will result in personal injury.
  - Repair or maintenance of the AC drive can be performed only by qualified personnel. Failure to comply will result in personal injury or damage to the AC drive.
  - Do not touch the components with your hands. Failure to comply will result in static electricity damage.

Other

-  **Warning**
- Self-reliant rebuilding is forbidden. Failure to comply will result in personal injury.

## Chapter 2 Product Information

### 2.1 Designation Rules

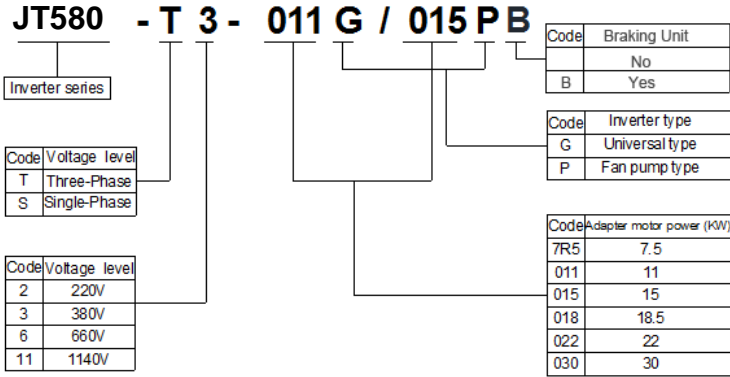

Figure 2.1 Designation rules

### 2.2 Nameplate

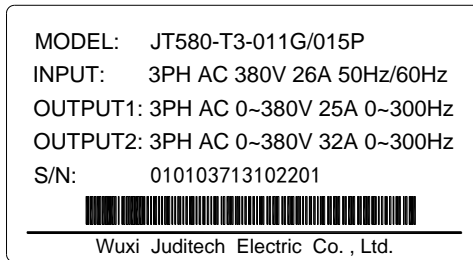

Figure 2.2 Data brand

### 2.3 JT580 Models and Technical Data

Table 2-1 JT580 models and data

Inverter types	Power capacity (KVA)	Input current (A)	Output current(A) G/P	Adapter motor (power) (horsepower) (KW) (HP)
Three-phase power supply: 380V,50/60Hz				
JT580-T3-0R7G/1R5PB	1.5	3.4	2.1	0.75 1
JT580-T3-1R5G/2R2PB	3	5	3.8	1.5 2
JT580-T3-2R2G/4R0PB	4	5.8	5.1	2.2 3
JT580-T3-4R0G/5R5PB	5.9	10.5	9	3.7 5
JT580-T3-5R5G/7R5PB	8.9	14.6	13	5.5 7.5
JT580-T3-7R5G/011PB	11	20.5	17	7.5 10



JT580-T3-011G/015PB	17	26	25	11	15
JT580-T3-015G/018PB	21	35	32	15	20
JT580-T3-018G/022PB	24	38.5	37	18.5	25
JT580-T3-022G/030PB	30	46.5	45	22	30
JT580-T3-030G/037P	40	62	60	30	40
JT580-T3-037G/045P	57	76	75	37	50
JT580-T3-045G/055P	69	92	91	45	60
JT580-T3-055G/075P	85	113	112	55	75
JT580-T3-075G/090P	114	157	150	75	100
JT580-T3-090G/110P	134	180	176	90	125
JT580-T3-110G/132P	160	214	210	110	150
JT580-T3-132G/160P	192	256	253	132	200
JT580-T3-160G/185P	231	307	304	160	210
JT580-T3-200G/220P	250	385	377	200	270

### 2.4 Product Description of Each Part

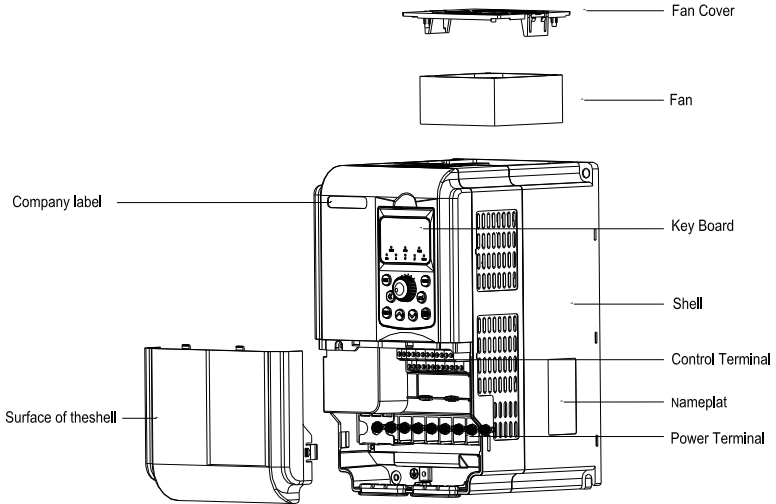

Figure 2.3 Name of components for plastic shell

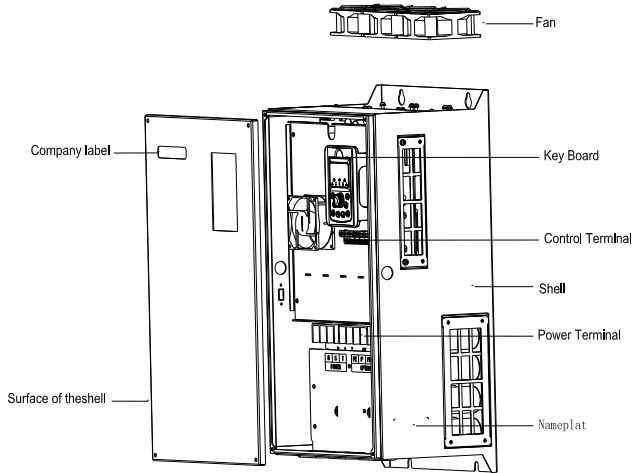

Figure 2.4 Name of components for metal plate shell

## 2.5 Technical Specifications

Table 2-2 Technical specifications of JT580

Project		Specification		
Standard functions	Maximum frequency	0~320Hz		
	Carrier frequency	0.5kHz~16.0kHz The carrier frequency is automatically adjusted based on the temperature		
	Input frequency resolution	Digital setting:0.01Hz Analog setting:maximum frequency $\times 0.025\%$		
	Control mode	Voltage/Frequency(V/F) control SVC: Sensorless Vector Control FVC : Feedback Vector Control		
	Startup torque	G type: 0.5Hz/150% (SVC); 0Hz/180% (FVC) P type: 0.5Hz/100%		
	Speed range	1:100(SVC)	1:1000(FVC)	
	Speed stability accuracy	$\pm 0.5\%$ (SVC)	$\pm 0.02\%$ (FVC)	
	Torque control accuracy	$\pm 5\%$ (FVC)		
	Overload capacity	G type: 60s for 150% of rated current and 3s for 180% of rated current P type: 60s for 120% of rated current and 3s for 150% of rated current		

	Torque boost	Automatic torque boost Manual torque boost 0.1%~30.0%
	V/F curve	Straight-line V/F curve Multi-point V/F curve Square V/F curve
	Ramp mode	Straight-line ramp S-curve ramp Four groups of acceleration/deceleration time with the range of 0.0–6500.0s
	DC braking	DC braking frequency: 0.00 Hz to maximum frequency Braking time: 0.0–100.0s Braking action current value: 0.0%~100.0%
	JOG control	JOG frequency range: 0.00–50.00 Hz JOG acceleration/deceleration time: 0.0–6500.0s
	Simple PLC, multi-speed running	It implements up to 16 speeds via the simple PLC function or combination of DI terminal states.
	Built-in PID	It implements the closed-loop process control system easily.
	Auto voltage regulation (AVR)	It can keep constant output voltage automatically when the mains voltage changes.
Standard functions	Overvoltage/Overcurrent stall control	The current and voltage are limited automatically during the running process so as to avoid frequent tripping due to overvoltage/overcurrent.
	Rapid current limit	It decreases the overcurrent faults to the minimum and ensures normal running of the AC drive.
	Torque limit and control	It can limit the torque automatically and prevent frequent over current tripping during the running process. Torque control can be implemented in the CLVC mode.
Individualized functions	High performance	Control of asynchronous motor is implemented through the high-performance current vector control technology.
	Run continuous in instantaneous power failure	The load feedback energy compensates the voltage reduction so that the inverter can continue to run for a short time.
	Timing control	Time range: 0.0–6500.0 minutes
	RS485 bus support	Modbus-RTU protocol
Running	Running command source	<ul style="list-style-type: none"> <li>• Operation panel control</li> <li>• Terminal control</li> <li>• Communication control</li> </ul> You can perform switch over between these sources in various ways.
	Frequency source	There are a total of five frequency sources, such as digital setting, analog voltage setting, analog current setting, pulse setting and communication setting,

		You can perform switch over between these sources in various ways.
	Auxiliary frequency source	There are a total of five frequency sources, such as digital setting, analog voltage setting, analog current setting, pulse setting and communication setting, It can implement fine tuning of auxiliary frequency and frequency synthesis.
	Input terminal	5 digital input (DI) terminals, X5 supports up to 100 kHz high-speed pulse input; 2 analog input (AI) terminals, AI1 only supports 0–10 V voltage input and AI2 supports 0–10 V voltage input or 0–20 mA current input.
	Output terminal	1 high-speed pulse output terminal (open-collector) that supports 0–100 kHz square wave signal output 1 digital output (DO) terminal 2 relay output terminals(One is factory default, the other is optional) 2 analog output (AO) terminals that supports 0–20 mA current output or 0–10 V voltage output.
Display and keyboard	LED display	Display parameters (three display modes: Basic mode, Quick menu mode, Non-factory value mode).
	Protection function	Motor short-circuit detection at power-on, input/output phase loss protection, overcurrent protection, over voltage protection, under voltage protection, overheat protection and overload protection.
	Optional parts	Braking unit, I/O extension card, RS485 communication card, differential input PG card, OC input PG card, sin/cos PG card.
Environment	Installation location	Indoor, free from direct sunlight, dust, corrosive gas, combustible gas, oil smoke, vapour, drip or salt.
	Altitude	Lower than 1000 m (derated if higher than 1000 m)
	Ambient temperature	-10 °C to +50 °C
	Humidity	Less than 95%RH, without condensing
	Vibration	Less than 5.9 m/s <sup>2</sup> (0.6 g)
	Storage temperature	-20°C~+60°C

Appearance and installation dimensions(mm)

a) Wall-mounted mounting dimensions

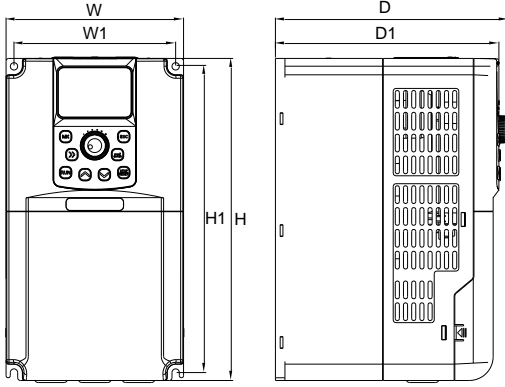

Figure2-5 Plastic shell mounting dimensions

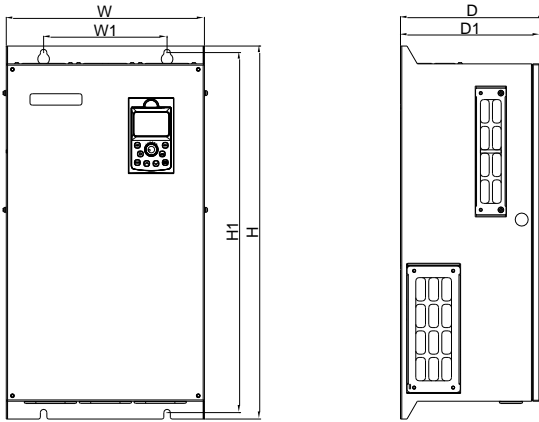

Figure2-6 Metal plate mounting dimensions

Table 2-3 Physical dimensions and mounting dimensions of the JT580 (mm)

Model	Mounting holes locations		Dimensions				Diameter of mounting hole
	W1	H1	H	W	D1	D	
JT580-T3-0R7G/1R5PB	88.4	168.4	180	100	152	159	φ5.5
JT580-T3-1R5G/2R2PB							
JT580-T3-2R2G/4R0PB							
JT580-T3-4R0G/5R5PB	118.4	224.5	236	130	163.5	170.5	φ5.5
JT580-T3-5R5G/7R5PB							

JT580-T3-7R5G/011PB	141	243	260	155	175	182	φ7
JT580-T3-011G/015PB							
JT580-T3-015G/018PB							
JT580-T3-018G/022PB	160	440	460	230	212	220	φ10
JT580-T3-022G/030PB							
JT580-T3-030G/037P	190	555	575	305	215	224	φ10
JT580-T3-037G/045P							
JT580-T3-045G/055P	230	643	670	390	290	298	φ12
JT580-T3-055G/075P							
JT580-T3-075G/090P	260	717	738	410	285	294	φ10
JT580-T3-090G/110P							
JT580-T3-110G/132P	320	780	810	455	315	324	φ12
JT580-T3-132G/160P							
JT580-T3-160G/185P	360	845	880	530	367	376	φ14
JT580-T3-200G/220P							

## 2.6 Appearance and Installation Size of the Keyboard

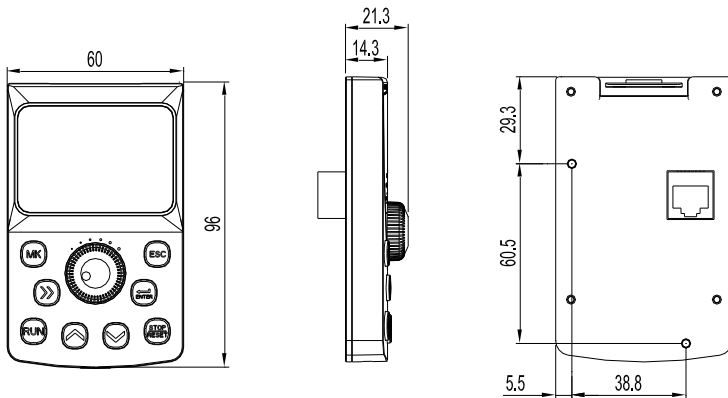

Figure 2.6 Appearance and installation size of the keyboard

## 2.7 Appearance and Hole Size of the Keyboard Tray

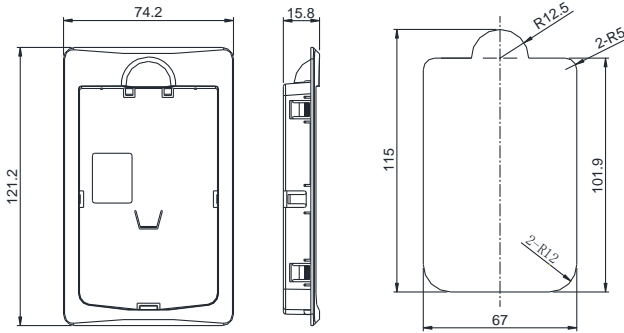
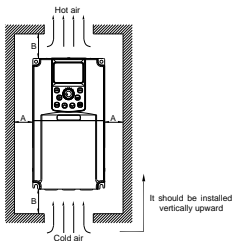

Figure 2.7 Keyboard tray appearance and hole size map

## Chapter 3 Mechanical Installation

### 3.1 Installation Environment

- 1) Environmental temperature: the ambient temperature has a great influence, should always keep the environment temperature under the inverter's allowed temperature range (-10 to 50 Degrees Celsius).
- 2) Install the inverter on the surface of an incombustible object, and ensure that there is sufficient space around for heat dissipation. Install the inverter vertically on the support using screws.
- 3) The vibration should be less than 0.6 g and the inverter should be installed far away from the punching machine or the like.
- 4) The mounting location should be free from direct sunlight, high humidity and condensation.
- 5) The mounting location should be free from corrosive, explosive and combustible gas.
- 6) The mounting location should be free from oil dirt, dust and metal powder.



Clearance Requirements	Clearance Requirements	
	A	B
0.75KW-22KW	A>10mm	B>100mm
30KW-37KW	A>50mm	B>200mm
45KW-75KW	A>50mm	B>200mm
90KW-630KW	A>50mm	B>300mm

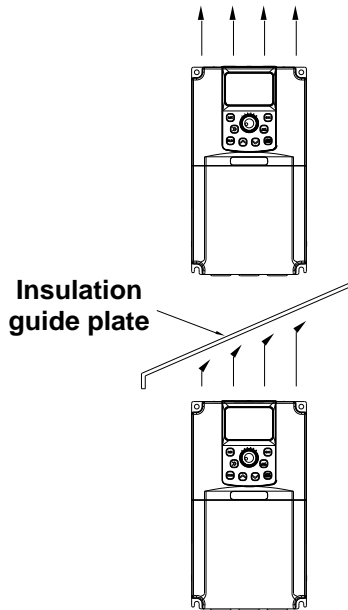

Figure 3.1 JT580 inverter installation diagram

Annotation: The size of “A” may not be considered when the inverter power is not greater than 22KW, but longer than 50mm when the inverter power is over 22KW.

Annotation: The heat guide plate is needed when the inverters are installed vertically next to each other.

#### **Attention matters for heat dissipation of mechanically mounting:**

- 1) The inverter should be installed vertically but not inverted for heat distribution. Side by side installing is highly considered for many inverters install in one cabinet. The heat guide plate should be set in vertical install situation, like Figure 3.1.
- 2) The installation space should follow Figure3.1 to ensure radiation space. But other parts heat dissipation should be considered when layout.
- 3) The mounting bracket must be flame retardant material.
- 4) The installation way of heat sink outside the cabinet is considered in the occasion of metal dust using. And the sealed cabinet space should be as large as possible.



### 3.2 The Disassembly of The Cover Plate

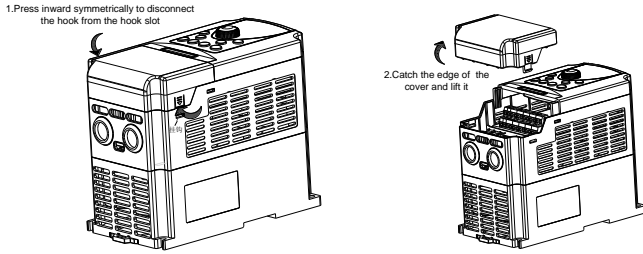

Figure 3.2 Disassembly of the cover plate (plastic shell)

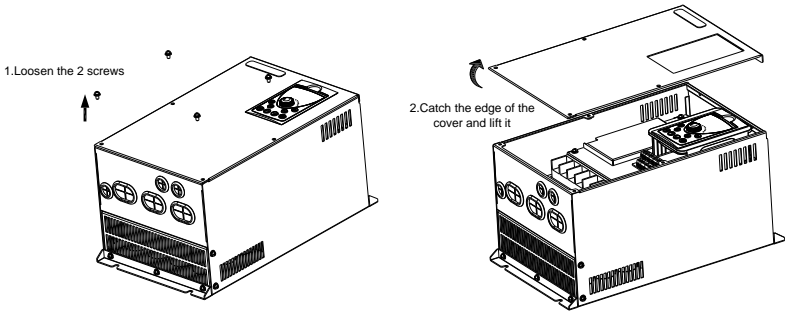

Figure 3.3 Disassembly of the cover plate (metal plate shell)

## Chapter 4 Electrical Installation

### 4.1 Electrical Installation

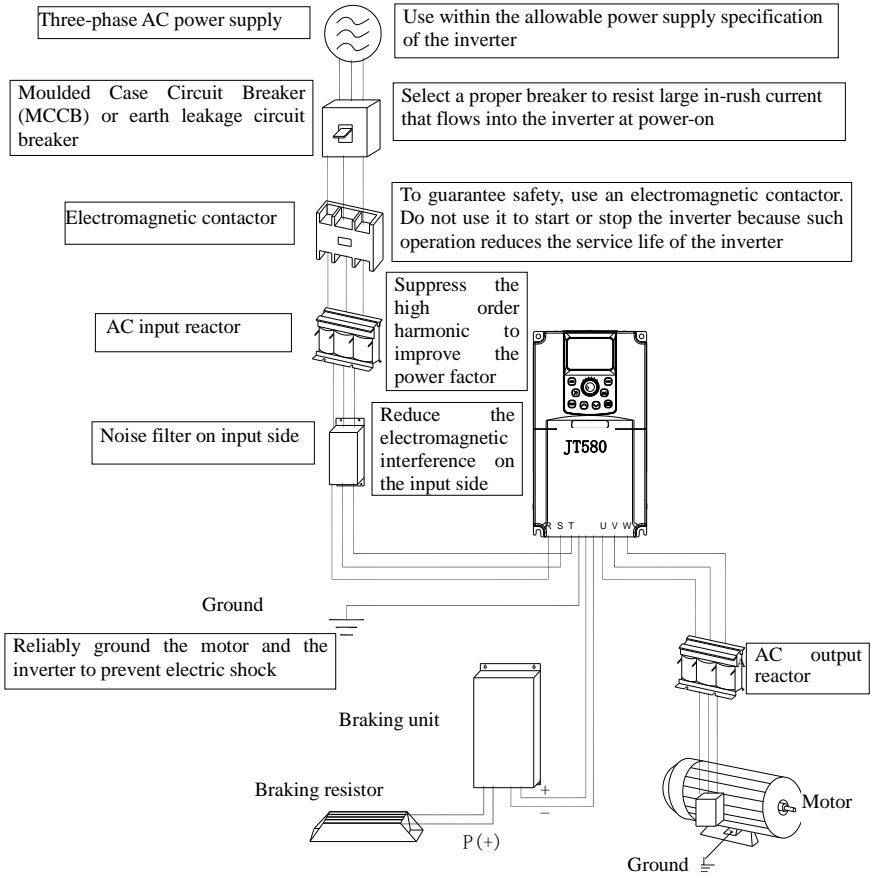

Figure 4.1 Peripheral electrical devices

- Do not install capacitors or surge suppressor in the output side of the inverter, this will lead to a breakdown or cause capacitance and the damaged of the surge suppressor.
- Input/Output (major loop) of the inverter contains harmonics, which may interfere with the communication device connected to the inverter. Therefore, anti-interference filters to minimize the interference are considered.
- The details of the peripheral devices and options refer to the selection manual of peripheral equipment.

## 4.2 Description of Peripheral Electrical Devices

Table 4-1 Description of peripheral electrical devices

Part	Function Description
MCCB	Interrupt the power supply when over current occurs on downstream devices
Contactor	Start and stop the inverter. Do not start and stop the inverter frequently by switching the contactor on and off (less than twice per minute) nor use it to directly start the inverter.
AC input reactor	<ul style="list-style-type: none"> <li>• Improve the power factor of the input side.</li> <li>• Eliminate the higher harmonics of the input side effectively and prevent other devices from being damaged due to distortion of the voltage waveform.</li> <li>• Eliminate the input current unbalance due to unbalance between the power phases.</li> </ul>
EMC Input filter	<ul style="list-style-type: none"> <li>• Reduce the external conduction and radiation interference of the inverter.</li> <li>• Decrease the conduction interference flowing from the power end to the inverter and improve the anti-interference capacity of the inverter.</li> </ul>
DC reactor	<ul style="list-style-type: none"> <li>• Improve the power factor of the input side.</li> <li>• Improve the efficiency and thermal stability of the inverter.</li> <li>• Eliminate the impact of higher harmonics of the inverter input side and reduce the external conduction and radiation interference.</li> </ul>
AC output reactor	<p>The output side of the inverter generally has much higher harmonics. When the motor is far from the inverter, there is much distributed capacitance in the circuit and certain harmonics may cause resonance in the circuit, bringing about the following two impacts:</p> <ul style="list-style-type: none"> <li>• Degrade the motor insulation performance and damage the motor in the long run.</li> <li>• Generate large leakage current and cause frequent inverter protection trips.</li> </ul> <p>If the distance between the inverter and the motor is greater than 100 m, install an AC output reactor.</p>

## 4.3 Peripheral Electrical Components Selection Guidance

Table 4-2 JT580 inverter peripheral electrical components selection guidance

Converter model	Open space (MCCB) (A)	Recommended contactor (A)	Recommended input side The main circuit wires (mm <sup>2</sup> )	Recommended output side The main circuit wires (mm <sup>2</sup> )	Recommended control Return conductor (mm <sup>2</sup> )
JT580-T3-0R7G/1R5PB	6	9	0.75	0.75	0.5
JT580-T3-1R5G/2R2PB	10	9	0.75	0.75	0.5
JT580-T3-2R2G/4R0PB	10	9	0.75	0.75	0.5
JT580-T3-4R0G/5R5PB	16	12	1.5	1.5	0.5
JT580-T3-5R5G/7R5PB	20	18	2.5	2.5	0.75
JT580-T3-7R5G/011PB	32	25	4.0	4.0	0.75
JT580-T3-011G/015PB	40	32	4.0	4.0	0.75
JT580-T3-015G/018PB	50	38	6.0	6.0	0.75

JT580-T3-018G/022PB	50	40	10	10	1.0
JT580-T3-022G/030PB	63	50	10	10	1.0
JT580-T3-030G/037P	100	65	16	16	1.0
JT580-T3-037G/045P	100	80	25	25	1.0
JT580-T3-045G/055P	125	95	35	35	1.0
JT580-T3-055G/075P	160	115	50	50	1.0
JT580-T3-075G/090P	225	170	70	70	1.0
JT580-T3-090G/110P	250	205	95	95	1.0
JT580-T3-110G/132P	315	245	120	120	1.0
JT580-T3-132G/160P	350	300	120	120	1.0
JT580-T3-160G/185P	400	300	150	150	1.0
JT580-T3-200G/220P	500	410	185	185	1.0

## 4.4 Selection of Braking Unit and Braking Resistor

### 4.4.1 Value selection of the Braking Resistor

The motor and load's regenerative energy is almost completely consumed on the braking resistor when braking.

According to the formula  $U \cdot U/R = P_b$ :

- U: the braking voltage at system stable braking.

Different systems select different braking voltages. The 380 VAC system usually selects 700 V braking voltage.

- $P_b$ : braking power.

### 4.4.2 Power selection of the Braking Resistor

In theory, the power of the braking resistor is consistent with the braking power. But in consideration that the derating is 70%, you can calculate the power of the braking resistor according to the formula  $0.7 \cdot P_r = P_b \cdot D$ .

- $P_r$ : the power of resistor.
- D: the braking frequency (percentage of the regenerative process to the whole working process)

Common Applications	Elevator	Uncoiling and coiling	Centrifuge	Accidental braking load	General occasions
Selection of the braking frequency	20%-30%	20%-30%	50%-60%	5%	10%

The following table provides data for reference. You can select different resistance and power based on actual need. However, the resistance value must not be smaller than the recommended value. The power may be larger than the recommended value.

The braking resistor model depends on the generation power of the motor in the actual system and is also related to the system's inertia, deceleration time and potential energy load. For systems with high inertia, and/or rapid deceleration times, or frequent braking sequences, the braking resistor with large power and small resistance value should be selected.

Table 4-3 Recommended values of braking resistor

Inverter Models	Braking resistance recommend power	Braking resistance recommend resistance	Brake unit
JT580-T3-0R7G/1R5PB	150W	$\geq 300\Omega$	Built-in (standard)
JT580-T3-1R5G/2R2PB	150W	$\geq 220\Omega$	
JT580-T3-2R2G/4R0PB	250W	$\geq 200\Omega$	
JT580-T3-4R0G/5R5PB	300W	$\geq 130\Omega$	
JT580-T3-5R5G/7R5PB	400W	$\geq 90\Omega$	
JT580-T3-7R5G/011PB	500W	$\geq 65\Omega$	
JT580-T3-011G/015PB	800W	$\geq 43\Omega$	
JT580-T3-015G/018PB	1.0KW	$\geq 32\Omega$	
JT580-T3-018G/022PB	1.3KW	$\geq 25\Omega$	
JT580-T3-022G/030PB	1.5KW	$\geq 22\Omega$	
JT580-T3-030G/037P	2.5KW	$\geq 16\Omega$	Built-in (optional)
JT580-T3-037G/045P	3.7 KW	$\geq 12.6\Omega$	
JT580-T3-045G/055P	4.5 KW	$\geq 9.4\Omega$	External
JT580-T3-055G/075P	5.5 kW	$\geq 9.4\Omega$	
JT580-T3-075G/090P	7.5 kW	$\geq 6.3\Omega$	
JT580-T3-090G/110P	4.5 kW ×2	$\geq 9.4\Omega \times 2$	
JT580-T3-110G/132P	5.5 kW ×2	$\geq 9.4\Omega \times 2$	
JT580-T3-132G/160P	6.5 kW ×2	$\geq 6.3\Omega \times 2$	
JT580-T3-160G/200P	16 kW	$\geq 6.3\Omega \times 2$	
JT580-T3-200G/220P	20 kW	$\geq 2.5\Omega$	

- " × 2" indicates that two braking units with their respective braking resistor are connected in parallel.
- " × 3" means the same to " × 2".

## 4.5 Wiring Method

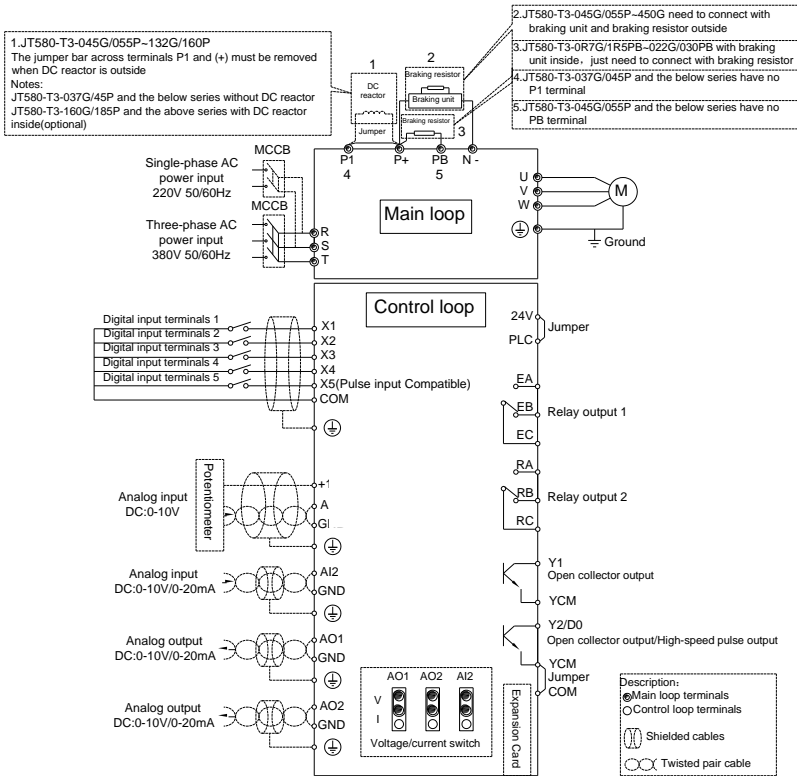

Figure 4.2 The model of wiring

Note:

1) Terminal ● is the major loop terminals, Terminal ○ is control circuit terminal.

2) The product models with "B" indicates the brake unit standard.

3) Braking resistor according to the user need to choose the Selection Guide.

4) Signal lines and power lines must be routed separately, if the control cables and power cables cross, as far as possible to make them according to the 90-degree angle cross. The analog signal line is best to use shielded twisted pair, power cable selection shielded three-core cable (its specifications than the average of the motor cable freshman profile) or to comply with the user manual of the inverter.

5) R is the standard relay, the relay E is optional.

### 4.5.1 Terminal Layout of Different Power Classes

1) Description of main circuit terminals of Single-phase:



Figure 4-3 Single-phase main circuit terminal layout

Table 4-4 Main circuit terminal description of single phase inverter

Symbol	Name	Function Description
L1、L2	Single-phase power supply input terminals	Connect to the single-phase 220 VAC power supply
(+)、(-)	Positive and negative terminals of DC bus	Common DC bus input point
(+)、PB	Connecting terminals of braking resistor	Connect to a braking resistor
U、V、W	inverter output terminals	Connect to a three-phase motor
	Grounding terminal	Must be grounded

2) Description of main circuit terminals of Three-phase:

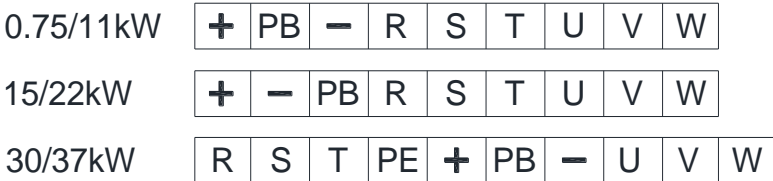



Figure 4-4 Three-phase main circuit terminal layout

Table 4-5 Main circuit terminal description of three phase inverter

Symbol	Name	Function Description
R、S、T	Three-phase power supply input terminals	Connect to the three-phase AC power supply
(+)、(-)	Positive and negative terminals of DC bus	Common DC bus input point Connect the external braking unit to the inverter of 45 kW and above
(+)、PB	Connecting terminals of braking resistor	Connect to the braking resistor for the inverter of 37 kW and below
U、V、W	inverter output terminals	Connect to a three-phase motor
	Grounding terminal	Must be grounded

**Precautions on Wiring**

**a) Power input terminals L1, L2 or R, S, T**

Inverter's input side wiring, phase sequence is not required.

**b) DC bus terminals (+), (-)**

- Terminals (+) and (-) of DC bus have residual voltage after the inverter is switched off. After indicator CHARGE goes off, wait at least 10 minutes before touching the equipment. Otherwise, you may get electric shock.

- connecting external braking components for the inverter of 37 kW and above, do not reverse poles (+) and (-). Otherwise, it may damage the inverter and even cause a fire.

- The cable length of the braking unit shall be no longer than 10 m. Use twisted pair wire or pair wires for parallel connection.

- Do not connect the braking resistor directly to the DC bus. Otherwise, it may damage the inverter and even cause fire.

**c) Braking resistor connecting terminals (+), PB**

- The connecting terminals of the braking resistor are effective only for the inverters configured with a built-in braking unit.

- The cable length of the braking resistor shall be less than 5 m. Otherwise, it may damage the inverter.

**d) Inverter output terminals U, V, W**

- The specification and installation method of external power cables must comply with the local safety regulations and related IEC standards.

- The capacitor or surge absorber cannot be connected to the output side of the inverter. Otherwise, it may cause frequent inverter fault or even damage the inverter.

- If the motor cable is too long, electrical resonance will be generated due to the impact of distributed capacitance. This will damage the motor insulation or generate higher leakage current, causing the inverter to trip in overcurrent protection. If the motor cable is greater than 100 m long, an AC output reactor must be installed close to the inverter.

**e) Terminal  $\oplus$  PE:**

- This terminal must be reliably connected to the main earthing conductor. Otherwise, it may cause electric shock, mal-function or even damage to the inverter.

- Do not connect the earthing terminal to the neutral conductor of the power supply.

4.5.2 Control Terminals and Wiring

1) Terminal arrangement of control circuit

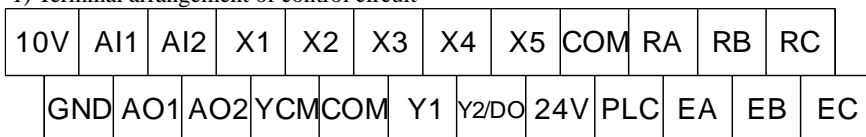

Figure 4.5 Control circuit terminal layout

2) Description of control circuit terminals

Table 4-6 Description of control circuit terminals

Type	Terminal	Name	Function Description
Power supply	+10V-GND	External +10 V power supply	Provide +10 V power supply to external unit. Generally, it provides power supply to external potentiometer with resistance range of 1–5 kΩ. Maximum output current: 10 mA
	24V-COM	External +24V power supply	Provide +24 V power supply to external unit. Generally, it provides power supply to input and output terminals and external sensors. Maximum output current: 200 mA
	PLC	External power input terminal	X input terminal of the power connector, the factory default control panel 24V with short, if you need an external 24V power supply, you need to jumper terminals on the control panel to remove the external 24V power to the PLC terminal
Power supply	YCM	Yn output terminal common terminal	Y1, Y2 two output terminals can be individually grounded, and control panel factory default COM shorted to ground alone if necessary, the need to control board jumpers removed, the terminal will be connected to the YCM



simulation Input	AI1-GND	Analog input terminal 1	1、 Input voltage range:DC 0V~10V 2、 Input impedance :22kΩ
	AI2-GND	Analog input terminal 2	1、 Input range: DC 0V ~10V /0mA ~20mA, decided by the AI2 jumper on the control board. 2、 Input impedance: 22 kΩ (voltage input), 500 Ω (current input)
Digital input	X1-COM	Digital input1	1、 Optical coupling isolation, compatible with dual polarity input 2、 Impedance: 2.4 kΩ 3、 Voltage range for level input: 9–30 V
	X2-COM	Digital input2	
	X3-COM	Digital input3	
	X4-COM	Digital input4	
	X5-COM	High-speed pulse input terminal	Besides features of X1 - X4, it can be used for high-speed pulse input. Maximum input frequency: 100 kHz
Analog output	AO1-GND	Analog output 1	Voltage or current output is decided by jumper AO1. Output voltage range: 0–10 V Output current range: 0–20 mA
	AO2-GND	Analog output 2	Output range:0V~10V/0mA~20mA Using the AO2 jumper on the left side of the control board to determine the voltage or current output.
Digital output	Y1-YCM	Digital output 1	Optical coupling isolation, dual polarity open collector output Output voltage range: 0–24 V Output current range: 0–50 mA Note that YCM and COM are internally insulated, but they are shorted by jumper externally.
	Y2-YCM	High-speed pulse output terminal	It is limited by F3.00 As high-speed pulse output, the maximum frequency hits 100 kHz. As open-collector output, it specification is the same as that of Y1
Relay output	R/B-R/C	R relay normally closed terminal	Contact actuation capability: AC250V,3A,COSφ=0.4. Relay E matching
	R/A-R/C	R relay normally open terminal	
Relay output	E/B-E/C	E relay normally closed terminal	Contact actuation capability: AC250V,3A,COSφ=0.4. Relay E matching
	E/A-E/C	E relay normally open terminal	

3) Wiring of control circuit terminals

①Wiring of AI terminals

Weak analog voltage signals are easy to suffer external interference, and therefore the shielded cable must be used and the cable length must be less than 20 m, as shown in following figure .

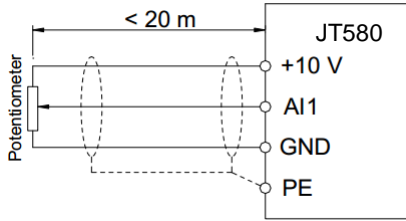

Figure 4.6 Wiring mode of AI terminals

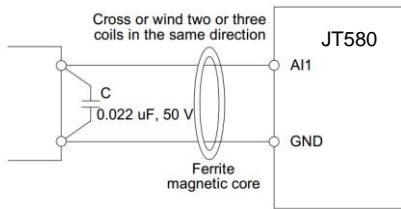

Figure 4.7 Wiring of AI terminals in special scenarios

②Wiring of DI terminals

Generally, select shielded cable no longer than 20 m. When active driving is adopted, necessary filtering measures shall be taken to prevent the interference to the power supply. It is recommended to use the contact control mode.

a. SINK wiring

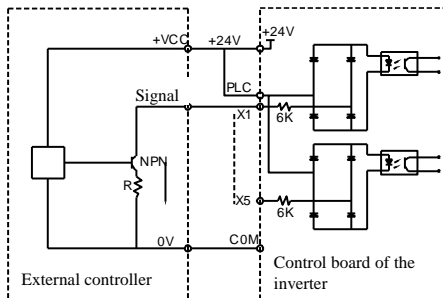

Figure 4.8 Wiring in SINK mode

This is one of the most commonly used connection mode. If you use an external power supply, you must put +24V and PLC short circuit between the COM and COM sheet and a short circuit between the sheet removed, the external power of positive electrode in the PLC, external power supply negative in COM.

b. SOURCE wiring

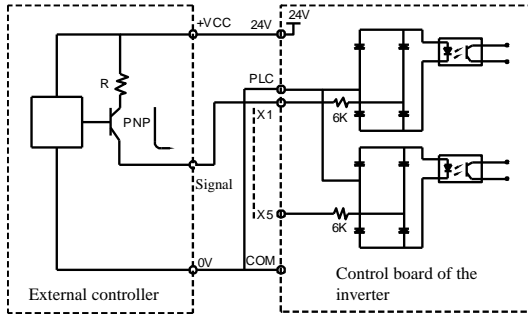

Figure 4.9 Wiring in SOURCE mode

This wiring must jump jumper J12 of PLC COM, the + 24V and public termination external controller together. If you use an external power supply, but also the negative external power supply must be connected to the PLC.

③Wiring of DO terminal

When the digital output terminal needs to drive the relay, an absorption diode shall be installed between two sides of the relay coil. Otherwise, it may cause damage to the 24V DC power supply.

Note: must be properly installed absorption of the polarity of the diode. As shown in Figure 4.8 or when the digital output terminal output, will immediately 24V DC power supply to burn.

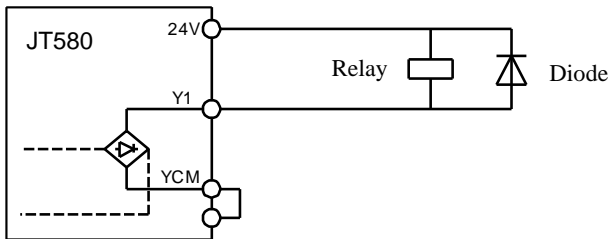

Figure 4.10 DO terminal wiring diagram

## Chapter 5 Operating and Display

### 5.1 Operation and Display Interface

Operation panel, the inverter function parameter modification, inverter working state monitoring and inverter control ( start, stop ) and other operations, its appearance and function area as shown below:

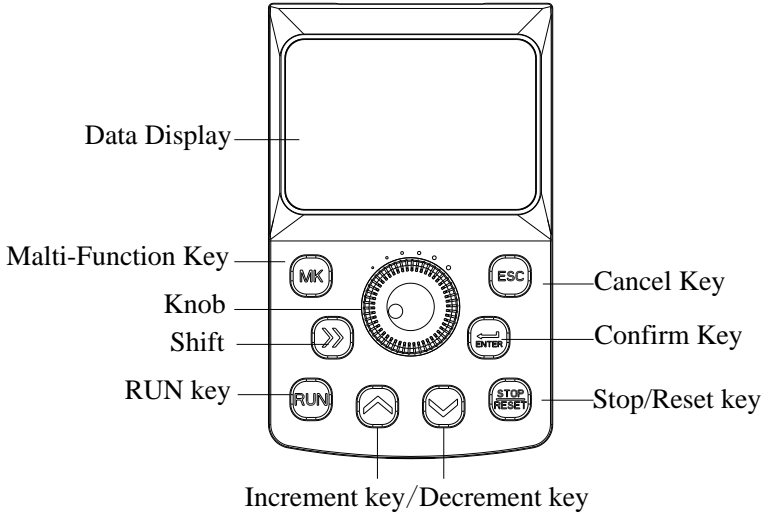

Figure 5.1 Keyboard display

### 5.2 Function Indicator Description

RUN: ON indicates that the inverter is in the running state, and OFF indicates that the AC drive is in the stop state.

ALM: Malfunction indicator light, when a fault occurs on the inverter, the light is on, normally is off.

Hz : Unit of frequency, light shows the corresponding parameter values of the units.

A : Unit of current.

V :Unit of voltage.

% : Percentage.

Rpm: Revolutions Per Minute.

F/R: Forward/Reverse.

### 5.3 Keyboard Button Description Table

Table 5-1 Keyboard function table

Button	Name	Function
MK	Multi-function keys	Programmable touch, positive / negative input switching function, function code display switching, start / stop

		command to switch, free parking and emergency stop, the specific function of a reference set of fifth chapter function code F0.26
ENTER	Confirm key	Step into the menu screen, set parameters confirmation
∧	Increment key	Increase data or function code
∨	Decrement key	Decrease data or function code
>>	Shift key	Select the displayed parameters in turn in the stop or running state, and select the digit to be modified when modifying parameters
ESC	Cancel key	Enter or exit Level I menu
RUN	RUN key	Start the inverter in the operation panel control mode
STOP/RESET	Stop / reset key	Stop the inverter when it is in the running state and perform the reset operation when it is in the fault state.

### 5.4 Viewing and Modifying Function Codes

The operation panel of the JT580 adopts three-level menu. The three-level menu consists of function code group (Level I), function code (Level II), and function code setting value (level III), as shown in the following Figure5.3.

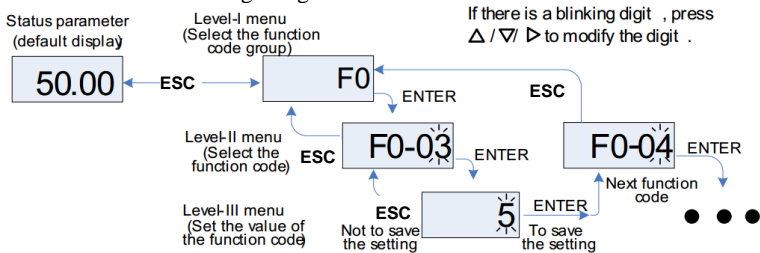

Figure 5.3 Operation procedure on the operation panel

You can return to Level II menu from Level III menu by pressing ESC or ENTER.

- After you press ENTER, the system saves the parameter setting first, and then goes back to Level II menu and shifts to the next function code.
- After you press ESC, the system does not save the parameter setting, but directly returns to Level II menu and remains at the current function code.

For example: the function code F2.03 changed from 12 set to 22.

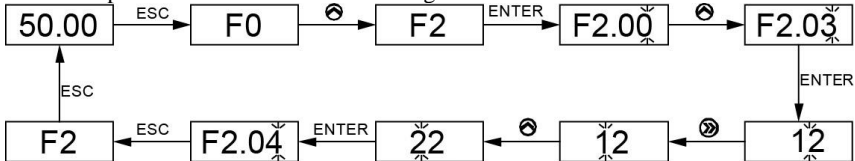

Figure 5.3 Example of changing the parameter value

In the third level menu state, if the parameter is not flashing, indicates that the feature codes cannot be modified, may cause:

- 1) The function code can not modify the parameters. If the actual detection parameters, log parameters;

2) The function code in the operating condition may not be modified, to be stopped only after the modification.

### 5.5 Selecting Menu Mode

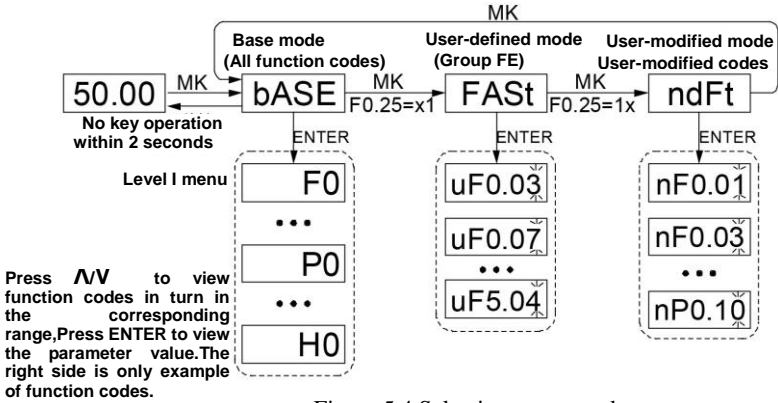

Figure 5.4 Selecting menu mode

## Chapter6 Function Parameter List

The symbols in the function code table are described as follow:

- “●” : The parameter can be modified when the inverter is in running state;
- “○” : The parameter cannot be modified when the inverter is in the running state;
- “◇” : The parameter is the actually measured value and cannot be modified;
- “X” :The parameter is factory parameter and can be set only by the manufacturer.

Function code	Parameter Name	Setting range	Default	Property
Group F0:Basic functional parameter groups				
F0.00	G/P type display	1: G type (constant torque load) 2: P type (variable torque load e.g. fan and pump)	Model dependent	○
F0.01	Motor control mode	0: Sensor-less flux vector control(SFVC) 1: Closed-loop vector control(CLVC) 2: Voltage/Frequency (V/F)control	2	○
F0.02	Command source selection	0: Operation panel control 1: Terminal control 2: Communication control	0	●
F0.03	Main frequency(X) source selection	0:Digital setting (non-retentive at power failure) 1: Digital setting (retentive at power failure) 2: AI1 3: AI2 4: AI3 5: Pulse setting (X5) 6: Multi-reference 7: Simple PLC 8: PID 9: Communication setting 10:AI1+AI2 11:AI1-AI2 12:max(AI1,AI2) 13:min(AI1,AI2)	4	○

Function code	Parameter Name	Setting range	Default	Property
F0.04	Auxiliary frequency(Y) source selection	The same as F0.03	0	○
F0.05	Range of auxiliary frequency Y for X and Y operation	0:Relative to the maximum frequency 1:Relative to the main speed	0	●
F0.06	Range of auxiliary frequency Y for X and Y	0%~150%	100.00%	●
F0.07	Frequency source selection	Unit's digit (Frequency source selection) 0: Main frequency source X 1: X and Y operation(operation relationship determined by ten's digit) 2: Switchover between X and Y 3: Switchover between X and "X and Y Operation" 4:Switchover between Y and "X and Y operation" Ten's digit (X and Y operation relationship) 0: X+Y 1: X-Y 2: Maximum 3: Minimum	00	●
F0.08	Digital frequency	0.00 to maximum frequency (valid when frequency source is digital setting)	50.00Hz	●
F0.09	Rotation direction	0: Same direction 1: Reverse direction	0	●
F0.10	Maximum frequency	50.00 Hz–320.00 Hz	50.00Hz	○
F0.11	Source of frequency upper limit	0: Set by F0.12 1: AI1 2: AI2 3: AI3 4: Pulse setting (X5) 5: Communication setting	0	○



Function code	Parameter Name	Setting range	Default	Property
F0.12	Frequency upper limit	Frequency lower limit (F0.14) to maximum frequency (F0.10)	50.00 Hz	●
F0.13	Frequency upper limit offset	0.00 Hz to maximum frequency(F0.10)	0.00 Hz	●
F0.14	Frequency lower limit	0.00 Hz to frequency upper limit(F0.12)	0.00 Hz	●
F0.15	Carrier frequency	0.5kHz~16.0 kHz	Model dependent	●
F0.16	Carrier frequency adjustment with temperature	0: No 1: Yes	1	●
F0.17	Acceleration time 1	0.00s~65000s	Model dependent	●
F0.18	Deceleration time 1	0.00s~65000s	Model dependent	●
F0.19	Frequency offset of auxiliary frequency source for X and Y operation	0.00 Hz to maximum frequency (F0.10)	0.00 Hz	●
F0.20	Digital set frequency Property selection	units' digit : stop memory options 0: no memory 1: memory Ten's digit: direct selection for UP/DN and analog operation 0: reversing 1: no reversing Hundred's digit: the UP/DN effective selection at stop 0: Valid 1: Invalid Thousand's digit: terminal UP/DN rate mode 0: frequency rate.F2.12 is rate, the unit for Hz/s 1: integral rate.F2.12 is time, the unit is "s".(only one decimal of F2.12 is effectively, the last two are ignored)	0	●
F0.21	Acceleration/ Deceleration time base frequency	0: Maximum frequency (F0.10) 1: Set frequency 2: 100 Hz	0	○

Function code	Parameter Name	Setting range	Default	Property
F0.22	Base frequency for UP/DOWN modification during running	0: Running frequency 1: Set frequency	0	○
F0.23	User password	0-65535	0	●
F0.24	Restore default settings	0: No operation 1: Restore factory settings except motor parameters 2: Clear records	0	○
F0.25	Individualized parameter display property	Unit's digit (Fast menu display selection) 0: Not display 1: Display Ten's digit (User-modified parameter display selection) 0: Not display 1: Display	00	●
F0.26	Parameter modification property	0: Modifiable 1: Not modifiable	0	●
F0.28	The number of decimal places	1: 1 decimal places 2: 2 decimal places	2	○
<b>Group F1: Motor 1 Parameters</b>				
F1.00	Motor model	0: Common asynchronous motor 1: Variable frequency asynchronous motor	0	○
F1.01	Motor rated power	0.1kW~1000.0kW	Model dependent	○
F1.02	Motor rated voltage	1V~2000V	Model dependent	○
F1.03	Motor rated current	0.01~655.35 A (inverter power ≤ 55 kW) 0.1~6553.5 A (inverter power > 55 kW)	Model dependent	○
F1.04	Motor rated frequency	0.01 Hz to maximum frequency	Model dependent	○
F1.05	Motor nominal speed	1~65535 RPM	Model dependent	○
F1.06	Motor stator resistance	0.001~65.535 Ω (inverter power ≤ 55 kW) 0.0001~6.5535 Ω (inverter power > 55 kW)	Tuning parameters	○

Function code	Parameter Name	Setting range	Default	Property
F1.07	Rotor resistance	0.001–65.535 Ω (inverter power ≤ 55 kW) 0.0001–6.5535 Ω (inverter power > 55 kW)	Tuning parameter s	○
F1.08	Leakage inductive reactance	0.01–655.35 mH (inverter power ≤ 55 kW) 0.001–65.535 mH (inverter power > 55 kW)	Tuning parameter s	○
F1.09	Mutual inductive reactance	0.1–6553.5 mH (inverter power ≤ 55 kW) 0.01–655.35 mH (inverter power > 55 kW)	Tuning parameter s	○
F1.10	No-load current	0.01 to F1-03 (inverter power ≤ 55 kW) 0.1 to F1-03 (inverter power > 55 kW)	Tuning parameter s	○
F1.27	Encoder pulses per revolution	1–65535	1024	○
F1.30	A/B phase sequence of ABZ incremental encoder	0: Forward 1: Reserve	0	○
F1.37	The parameters self-identification	0:Not identification 1:Motor stationary self-identification 2:Motor rotation self-identification	0	○
<b>Group F2: Input Terminals</b>				
F2.00	X1 function selection	0: No function	1	○
F2.01	X2 function selection	1: Forward RUN (FWD)	4	○
F2.02	X3 function selection	2: Reverse RUN (REV)	9	○
F2.03	X4 function selection	3: Three-line control	12	○
F2.04	X5 function selection	4: Forward JOG (FJOG)	13	○
F2.05	X6 function selection	5: Reverse JOG (RJOG)	0	○
F2.06	X7 function selection	6: Terminal UP	0	○
F2.07	X8 function selection	7: Terminal DOWN	0	○
F2.08	X9 function selection	8: Coast to stop	0	○
		9: Fault reset (RESET)	0	○
		10: RUN pause		
F2.09	X10 function selection	11: Normally open (NO) input of external fault 12: Multi-reference terminal 1	0	○

Function code	Parameter Name	Setting range	Default	Property
		13: Multi-reference terminal 2 14: Multi-reference terminal 3 15: Multi-reference terminal 4 16: Terminal 1 for acceleration/deceleration time selection 17: Terminal 2 for acceleration/deceleration time selection 18: Frequency source switch over 19: UP and DOWN setting clear (terminal, operation panel) 20: Command source switch over keyboard 21: Acceleration /Deceleration prohibited 22: PID pause 23: PLC status reset 24: Swing pause 25: Counter input 26: Counter reset 27: Length count input 28: Length reset 29: Torque control prohibited 30: Pulse input (enabled only for X5) 31:Reserved 32: Immediate DC braking 33: Normally closed (NC) input of external fault 34: Frequency modification forbidden 35: Reverse PID action direction 36: External STOP terminal 1 37: Command source switch over terminal 38: PID integral pause		

Function code	Parameter Name	Setting range	Default	Property
		39: Switch over between main frequency source X and digital Frequency 40: Switch over between auxiliary frequency source Y and digital frequency 41: PID parameters switch over 42: User-defined fault 1 43: User-defined fault 2 44: Speed control/Torque control switch over 45: Emergency stop 46: External STOP terminal 2 47: Deceleration DC braking 48: Clear the current running time		
F2.10	X filter time	0.000s~1.000s	0.010s	●
F2.11	Terminal command mode	0: Two-line mode 1 1: Two-line mode 2 2: Three-line mode 1 3: Three-line mode 2	0	○
F2.12	Terminal UP/DOWN rate	0.01Hz/s~65.535 Hz/s	1.00Hz/s	●
F2.13	AI1 filter time	0.00s~10.00s	0.10s	●
F2.14	AI2 filter time	0.00s~10.00s	0.10s	●
F2.15	AI3 filter time	0.00s~10.00s	0.10s	●
F2.16	AI curve 1 minimum input	0.00V~F2.18	0.20V	●
F2.17	Corresponding setting of AI curve 1 minimum input	-100.0%~+100.0%	0.0%	●
F2.18	AI curve 1 maximum input	F2.16~+10.00V	10.00V	●
F2.19	Corresponding setting of AI curve 1 maximum input	-100.0%~+100.0%	100.0%	●
F2.20	AI curve 2 minimum input	0.00V~F2.22	0.20V	●
F2.21	Corresponding setting of AI curve 2 minimum input	-100.0%~+100.0%	0.0%	●
F2.22	AI curve 2 maximum input	F2.20~+10.00V	10.00V	●

Function code	Parameter Name	Setting range	Default	Property
F2.23	Corresponding setting of AI curve 2 maximum input	-100.0%~+100.0%	100.0%	●
F2.24	AI curve 3 minimum input	0.00V~F2.26	0.20V	●
F2.25	Corresponding setting of AI curve 3 minimum input	-100.0%~+100.0%	0.0%	●
F2.26	AI curve 3 maximum input	F2.24~+10.00V	10.00V	●
F2.27	Corresponding setting of AI curve 3 maximum input	-100.0%~+100.0%	100.0%	●
F2.28	PULSE minimum input	0.00kHz~F2.30	0.00kHz	●
F2.29	Corresponding setting of PULSE minimum input	-100.0%~100.0%	0.0%	●
F2.30	PULSE maximum input	F2.28~100.00kHz	50.00kHz	●
F2.31	Corresponding setting of PULSE maximum input	-100.0%~100.0%	100.0%	●
F2.32	PULSE filter time	0.00s~10.00s	0.10s	●
F2.33	AI curve selection	Unit's digit (AI1 curve selection) Curve 1 ( 2 points, see F2.16 to F2.19) Curve 2 ( 2 points, see F2.20 to F2.23) Curve 3 ( 2 points, see F2.24 to F2.27) Curve 4 ( 4 points, see P0.00 to P0.07) Curve 5 ( 4 points, see P0.08 to P0.15) Ten's digit (AI2 curve selection) Curve 1 to curve 5 (same as AI1) Hundred's digit (AI3 curve selection) Curve 1 to curve 5 (same as AI1)	321	●
F2.34	Setting for AI less than minimum input	Unit's digit (Setting for AI1 less than minimum input) 0: Minimum value 1: 0.0%	000	●

Function code	Parameter Name	Setting range	Default	Property
		Ten's digit (Setting for AI2 less than minimum input) 0, 1 (same as AI1) Hundred's digit (Setting for AI3 less than minimum input) 0, 1 (same as AI1)		
F2.35	X1 delay time	0.0s~3600.0s	0.0s	○
F2.36	X2 delay time	0.0s~3600.0s	0.0s	○
F2.37	X3 delay time	0.0s~3600.0s	0.0s	○
F2.38	X valid mode selection	0: High level valid 1: Low level valid Unit's digit:X1 Ten's digit:X2 Hundred's digit:X3 Thousand's digit:X4 Ten thousand's digit:X5		
<b>Group F3:Output Terminals</b>				
F3.00	Y2/DO terminal output mode	0:Pulse output (DO) 1:Switch signal output (Y2)	1	●
F3.01	Y1 output function selection	0: No output 1: inverter running 2: Fault output (stop) 3: Frequency-level detection FDT1 output 4: Frequency reached 5: Zero-speed running (no output at stop) 6: Motor overload pre-warning 7: inverter overload pre-warning 8: Set count value reached 9: Designated count value reached 10: Length reached 11: PLC cycle complete 12: Accumulative running time reached 13: Frequency limited 14: Torque limited 15: Ready for RUN 16: AI1 larger than AI2 17: Frequency upper	1	●
F3.02	Y2 output function selection		0	●
F3.03	R relay output function selection		2	●
F3.04	E relay output function selection		0	●

Function code	Parameter Name	Setting range	Default	Property
		limit reached 18: Frequency lower limit reached(no output at stop) 19: Under voltage state output 20: Communication setting 21: Reserved 22: Reserved 23: Zero-speed running 2 (having output at stop) 24: Accumulative power-on time reached 25: Frequency level detection FDT2 output 26: Frequency 1 reached 27: Frequency 2 reached 28: Current 1 reached 29: Current 2 reached 30: Timing reached 31: All input limit exceeded 32: Load becoming 0 33: Reverse running 34: Zero current state 35: Module temperature reached 36: Software current limit exceeded 37: Frequency lower limit reached(having output at stop) 38: Alarm output 39: Motor overheat warning 40: Current running time reached 41: Analog levels:ADT1 42: Analog levels:ADT2 44: The X1 state 45: The X2 state		
F3.05	Reserved		0	●
F3.06	DO output function selection	0: Running frequency 1: Set frequency	0	●
F3.07	AOI output function selection	2: Output current 3: Output torque	0	●



Function code	Parameter Name	Setting range	Default	Property
F3.08	AO2 output function selection	(absolute value) 4: Output power 5: Output voltage 6: Pulse input 7: AI1 8: AI2 9: AI3 10: Length 11: Count value 12: Communication setting 13: Motor rotational speed 14: Output current 15: Output voltage 16:Reservation	1	●
F3.09	Maximum output Frequency of DO	0.01kHz~100.00kHz	50.00kHz	●
F3.10	AO1 offset coefficient	-100.0%~+100.0%	0.0%	●
F3.11	AO1 gain	-10.00~+10.00	1.00	●
F3.12	AO2 offset coefficient	-100.0%~+100.0%	0.0%	●
F3.13	AO2 gain	-10.00~+10.00	1.00	●
F3.14	Y1output delay time	0.0s~3600.0s	0.0s	●
F3.15	Y2output delay time	0.0s~3600.0s	0.0s	●
F3.16	R output delay time	0.0s~3600.0s	0.0s	●
F3.17	E output delay time	0.0s~3600.0s	0.0s	●
F3.18	Reservation			●
F3.19	Output terminals valid mode selection	0: Positive logic 1: Negative logic Unit's digit:Y1 Ten's digit:Y2 Hundred's digit:R Thousand's digit:E	0000	●
<b>Group F4: Auxiliary Functions</b>				
F4.00	JOG running frequency	0.00 Hz to maximum frequency	2.00Hz	●
F4.01	JOG acceleration time	0.0s~6500.0s	20.0s	●
F4.02	JOG deceleration time	0.0s~6500.0s	20.0s	●
F4.03	Acceleration time 2	0.0s~6500.0s	Model dependent	●
F4.04	Deceleration time 2	0.0s~6500.0s	Model dependent	●
F4.05	Acceleration time 3	0.0s~6500.0s	Model dependent	●
F4.06	Deceleration time 3	0.0s~6500.0s	Model dependent	●

Function code	Parameter Name	Setting range	Default	Property
F4.07	Acceleration time 4	0.0s~6500.0s	Model dependent	●
F4.08	Deceleration time 4	0.0s~6500.0s	Model dependent	●
F4.09	Jump frequency 1	0.00 Hz to maximum frequency	0.00Hz	●
F4.10	Jump frequency 2	0.00 Hz to maximum frequency	0.00Hz	●
F4.11	Frequency jump amplitude	0.00 Hz to maximum frequency	0.01Hz	●
F4.12	Forward/Reverse rotation dead-zone time	0.0s~3000.0s	0.0s	●
F4.13	Reverse control	0: Enabled 1: Disabled	0	●
F4.14	Running mode when set frequency lower than frequency lower limit	0: Run at frequency lower limit 1: Stop 2: Run at zero speed	0	●
F4.15	Droop control	0.00Hz~10.00Hz	0.00Hz	●
F4.16	Accumulative power-on time threshold	0h~65000h	0h	●
F4.17	Accumulative running time threshold	0h~65000h	0h	●
F4.18	Startup protection	0: No 1: Yes	0	●
F4.19	Frequency detection value(FDT1)	0.00 Hz to maximum frequency	50.00Hz	●
F4.20	Frequency detection hysteresis(FDT hysteresis 1)	0.0%~100.0% (F4.19)	5.0%	●
F4.21	Detection range of frequency reached	0.0%~100.0% (maximum frequency)	0.0%	●
F4.22	Jump frequency during acceleration /deceleration	0: Disabled 1: Enabled	0	●
F4.25	Frequency switch over point between acceleration time 1 and acceleration time 2	0.00 Hz to maximum frequency	0.00Hz	●
F4.26	Frequency switch over point between deceleration time 1 and deceleration time 2	0.00 Hz to maximum frequency	0.00Hz	●

Function code	Parameter Name	Setting range	Default	Property
F4.27	Terminal JOG preferred	0: Disabled 1: Enabled	0	●
F4.28	Frequency detection value(FDT2)	0.00 Hz to maximum frequency	50.00Hz	●
F4.29	Frequency detection hysteresis(FDT hysteresis 2)	0.0% - 100.0% (FDT2 level)	5.0%	●
F4.30	Any frequency reaching detection value 1	0.00 Hz to maximum frequency	50.00Hz	●
F4.31	Any frequency reaching detection amplitude 1	0.0%~100.0% (maximum frequency)	0.0%	●
F4.32	Any frequency reaching detection value 2	0.00 Hz to maximum frequency	50.00Hz	●
F4.33	Any frequency reaching detection amplitude 2	0.0%~100.0% (maximum frequency)	0.0%	●
F4.34	Zero current detection level	0.0%~300.0% 100.0% correspond to rated motor current	5.0%	●
F4.35	Zero current detection delay time	0.01s~600.00s	0.10s	●
F4.36	Output overcurrent threshold	0.0% (no detection) 0.1% - 300.0% (rated motor current)	200.0%	●
F4.37	Output overcurrent detection delay time	0.00s~600.00s	0.00s	●
F4.38	Any current reaching 1	0.0% - 300.0%(rated motor current)	100.0%	●
F4.39	Any current reaching 1 amplitude	0.0%~300.0%(rated motor current)	0.0%	●
F4.40	Any current reaching2	0.0%~300.0%(rated motor current)	100.0%	●
F4.41	Any current reaching 2 amplitude	0.0%~300.0%(rated motor current)	0.0%	●
F4.42	Timing function	0: Disabled 1: Enabled	0	●
F4.43	Timing duration source	0:F4.44 1:AI1 2:AI2 3:AI3(100% of analog input corresponds to the value of F4.44)	0	●
F4.44	Timing duration	0.0Min~6500.0Min	0.0Min	●
F4.45	AI1 input voltage lower limit	0.00V~F4.46	3.10V	●
F4.46	AI1 input voltage upper limit	F4.45~10.00V	6.80V	●

Function code	Parameter Name	Setting range	Default	Property
F4.47	Module temperature threshold	0°C~100°C	75°C	●
F4.48	Cooling fan control	0: Fan working during running 1: Fan working continuously	0	●
F4.49	Wakeup frequency	Dormant frequency (F4.51) to maximum frequency (F0.10)	0.00Hz	●
F4.50	Wakeup delay time	0.0s~6500.0s	0.0s	●
F4.51	Dormant frequency	0.00Hz to wakeup frequency (F4.49)	0.00Hz	●
F4.52	Dormant delay time	0.0s~6500.0s	0.0s	●
F4.53	Current running time reached	0.0Min~6500.0Min	0.0Min	●
F4.54	ADT1channel selection	Unit's digit: 0:AI1 1:AI2 Ten's digit: 0:No output at stop 1:having output at stop	00	●
F4.55	ADT2channel selection	Unit's digit: 0:AI1 1:AI2 Ten's digit: 0:No output at stop 1:having output at stop	01	●
F4.56	ADT1 output upper limit	F4.57~10.00	10.00V	●
F4.57	ADT1 output lower limit	0.00~F4.56	0.00V	●
F4.58	ADT2 output upper limit	F4.59~10.00	10.00V	●
F4.59	ADT2 output lower limit	0.00~F4.58	0.00V	●
<b>Group F5: Vector Control Functions</b>				
F5.00	Speed loop proportional gain 1	1~100	30	●
F5.01	Speed loop integral time 1	0.01s~10.00s	0.50s	●
F5.02	Switchover frequency 1	0.00~A2.05	5.00Hz	●
F5.03	Speed loop proportional gain 2	1~100	20	●
F5.04	Speed loop integral time 2	0.01s~10.00s	1.00s	●
F5.05	Switchover frequency 2	F5.02to maximum output frequency	10.00Hz	●

Function code	Parameter Name	Setting range	Default	Property
F5.06	Vector control slip gain	50%~200%	100%	●
F5.07	Time constant of speed loop filter	0.000s~0.100s	0.000s	●
F5.08	Vector control over-excitation gain	0~200	64	●
F5.09	Torque upper limit source in speed control mode control mode	0: F5.10 1: AI1 2: AI2 3: AI3 4: Pulse setting (X5) 5: Communication setting 6: MIN(AI1,AI2) 7: MAX(AI1,AI2) Full scale of the above(1-7) corresponds to F5.10	0	●
F5.10	Digital setting of torque upper limit in speed control mode	0.0%~200.0%	150.0%	●
F5.11	Upper Limit of Torque Source in Speed Control Mode(In Regenerative State)	0: F5.12 1: AI1 2: AI2 3: AI3 4: Pulse Setting (X5) 5: Communication Setting 6: MIN(AI1,AI2) 7: MAX(AI1,AI2)	0	●
F5.12	Digital Setting of Torque Upper Limit in Speed Control Mode(In Regenerative State)	0.0%~200.0%	150.0%	●
F5.13	Excitation adjustment proportional gain	0~60000	2000	●
F5.14	Excitation adjustment integral gain	0~60000	1300	●
F5.15	Torque adjustment proportional gain	0~60000	2000	●
F5.16	Torque adjustment integral gain	0~60000	1300	●

Function code	Parameter Name	Setting range	Default	Property
<b>Group F6: V/F Control Parameters</b>				
F6.00	V/F curve setting	0: Linear V/F 1: Multi-point V/F 2: Square V/F 3: 1.2-power V/F 4: 1.4-power V/F 6: 1.6-power V/F 8: 1.8-power V/F	0	○
F6.01	Torque boost	0.0%:(fixed torque boost) 0.1%~30.0%	Model dependent	●
F6.02	Cut-off frequency of torque boost	0.00 Hz to maximum output frequency	50.00Hz	○
F6.03	Multi-point V/F frequency 1	0.00Hz~F6.05	0.00Hz	○
F6.04	Multi-point V/F voltage 1	0.0%~100.0%	0.0%	○
F6.05	Multi-point V/F frequency 2	F6.03~F6.07	0.00Hz	○
F6.06	Multi-point V/F voltage 2	0.0%~100.0%	0.0%	○
F6.07	Multi-point V/F frequency 3	F6.05to rated motor frequency (F1.04)	0.00Hz	○
F6.08	Multi-point V/F voltage 3	0.0%~100.0%	0.0%	○
F6.09	V/F slip compensation gain	0.0%~200.0%	0.0%	●
F6.10	V/F over-excitation gain	0~200	64	●
F6.11	V/F oscillation suppression gain	0~100	Model dependent	●
F6.13	Limited flow protection function selection	0~1	0	○
F6.14	Current limiting protection value	0~600	70A	●
F6.15	Limited current protection action time	0.0~60.0	02.0s	●
<b>Group F7: Start/Stop Control Parameters</b>				
F7.00	Start mode	0: Direct start 1: Rotational speed tracking restart 2: Dc brake restart	0	●
F7.01	Rotational speed tracking mode	0: From frequency at stop 1: From zero speed 2: From maximum frequency	0	○
F7.02	Rotational speed tracking speed	1~100	20	●

Function code	Parameter Name	Setting range	Default	Property
F7.03	Startup frequency	0.00Hz~10.00Hz	0.00Hz	●
F7.04	Startup frequency holding time	0.0s~100.0s	0.0s	○
F7.05	Startup DC braking current	0%~100%	0%	○
F7.06	Startup DC braking time	0.0s~100.0s	0.0s	○
F7.07	Acceleration/Deceleration mode	0: Linear acceleration/deceleration 1: S-curve acceleration/deceleration A 2: S-curve acceleration/deceleration B	0	○
F7.08	Time proportion of S-curve start segment	0.0%~ ( 100.0%-F7.09 )	30.0%	○
F7.09	Time proportion of S-curve end segment	0.0%~ ( 100.0%-F7.08 )	30.0%	○
F7.10	Stop mode	0: Decelerate to stop 1: Coast to stop	0	●
F7.11	Initial frequency of stop DC braking	0.00 Hz to maximum frequency	0.00Hz	●
F7.12	Waiting time of stop DC braking	0.0s~100.0s	0.0s	●
F7.13	Stop DC braking current	0%~100%	0%	●
F7.14	Stop DC braking time	0.0s~100.0s	0.0s	●
F7.15	Brake use ratio	0%~100%	100%	●
<b>Group F8: Operation Panel and Display Parameters</b>				
F8.01	MK Key function selection	0: Menu to switch 1: Switchover between operation panel control and remote command control (terminal or communication) 2: Switchover between forward rotation and reverse rotation 3: Forward JOG 4: Reverse JOG	0	○

Function code	Parameter Name	Setting range	Default	Property
F8.02	STOP/RESET key function	0: STOP/RESET key enabled only in operation panel control 1: STOP/RESET key enabled in any operation mode	1	●
F8.03	LED display running parameters 1	0000–FFFF Bit00: Running frequency (Hz) Bit01: Set frequency (Hz) Bit02: Output current (A) Bit03: Output voltage (V) Bit04: Output power (kW) Bit05: Output torque (%) Bit06: Bus voltage (V) Bit07: X input status 1 Bit08: Reservations	1F	●
		Bit09: Digital output status Bit10: AI1 voltage (V) Bit11: AI2 voltage (V) Bit12: AI3 voltage (V) Bit13: Pulse setting frequency(kHz) Bit14: PID setting Bit15: PID feedback		
F8.04	LED display running parameters 2	0000–FFFF Bit00: PID output Bit01: Load speed display Bit02: Main frequency display(Hz) Bit03: Auxiliary frequency display (Hz) Bit04: Feedback speed Bit05: Count value Bit06: Length value Bit07: Linear speed Bit08: Current power-on time(Hour) Bit09: Current running		



		time (Min) Bit10:Overload count Bit11:Output current percentage(%) Bit12:Remaining running time Bit13: PLC stage Bit14:Communication setting value		
F8.05	LED display stop parameters	0000~FFFF Bit00: Set frequency (Hz) Bit01: Bus voltage (V) Bit02: X input status Bit03: Digital output status Bit04: AI1 voltage (V) Bit05: AI2 voltage (V) Bit06: AI3 voltage (V) Bit07: Count value Bit08: Length value Bit09: PLC stage Bit10: Load speed Bit11: PID setting Bit12:Pulse setting frequency (kHz)	33	●
F8.06	Load speed display coefficient	0.0001~6.5000	3.0000	●
F8.07	Heatsink temperature of inverter module	0.0°C~100.0°C		◇
F8.09	Accumulative running time	0h~65535h		◇
F8.11	Software version			◇
F8.12	Number of decimal places for load speed	0: 0 decimal place 1: 1 decimal place 2: 2 decimal places	1	●
<b>Group F9: Fault and Protection Parameters</b>				
	display	3: 3 decimal places		
F8.13	Accumulative power-on time	0h~65535h		◇
F8.14	Accumulative power consumption	0~65535 kWh		◇
F9.00	Motor overload protection selection	0: Disabled 1: Enabled	1	●
F9.01	Motor overload protection gain	0.20~10.00	1.00	●
F9.02	Motor overload warning coefficient	50%~100%	80%	●

Function code	Parameter Name	Setting range	Default	Property
F9.03	Overvoltage stall gain	0~100	0	●
F9.04	Overvoltage stall protective voltage	120%~150%	130%	●
F9.05	Overcurrent stall gain	0~100	20	●
F9.06	Overcurrent stall protective current	100%~200%	150%	●
F9.07	Short-circuit to ground upon power-on	0: Disabled 1: Enabled	1	●
F9.09	Fault auto reset times	0~20	0	●
F9.10	X action during fault auto reset	0: Not act 1: Act	0	●
F9.11	Time interval of fault auto reset	0.1s~100.0s	1.0s	●
F9.12	Input phase loss protection/contactor energizing protection selection	Unit's digit: Input phase loss protection Ten's digit: Contactor energizing protection 0: Disabled 1: Enabled	10	●
F9.13	Output phase loss protection selection	0: Disabled 1: Enabled	1	●
F9.14	1st fault type	0: No fault	—	◇
F9.15	2nd fault type	1: Reserved		
F9.16	3rd (latest) fault type	2: Overcurrent during acceleration 3: Overcurrent during deceleration 4: Overcurrent at constant speed 5: Overvoltage during acceleration 6: Overvoltage during deceleration 7: Overvoltage at constant speed 8: Buffer resistance overload 9: Undervoltage 10: inverter overload 11: Motor overload 12: Power input phase loss 13: Power output phase loss 14: Module overheat 15: External equipment fault	—	◇

		16: Communicationfault 17: Contactor fault 18: Current detection fault 19: Motor auto-tuning fault 20: Encoder/PG card fault 21: EEPROM read-write fault 22: inverter hardware fault 23: Short circuit to ground 24: Reserved 25: Reserved 27: User-defined fault 1 28: User-defined fault 2 29:Accumulative power-on time reached 30: Load becoming 0 31:PID feedback lost during running 40:With-wave current limit fault 42:Too large speed deviation 43: Motor over-speed 51: Initial position fault		
F9.17	Frequency upon 3rd fault	—	—	◇
F9.18	Current upon 3rd fault	—	—	◇
F9.19	Bus voltage upon 3rd fault	—	—	◇
F9.20	Input terminal status upon 3rd fault	—	—	◇
F9.21	The inverter temperature upon 3rd fault	—	—	◇
F9.22	inverter status upon 3rd fault	—	—	◇
F9.23	Power-on time upon 3rd fault	—	—	◇
F9.24	Running time upon 3rd fault	—	—	◇
F9.27	Frequency upon 2nd fault	—	—	◇
F9.28	Current upon 2nd fault	—	—	◇
F9.29	Bus voltage upon 2nd fault	—	—	◇

Function code	Parameter Name	Setting range	Default	Property
F9.30	X status upon 2nd fault	—	—	◇
F9.31	The inverter temperature upon 2nd fault	—	—	◇
F9.32	inverter status upon 2nd fault	—	—	◇
F9.33	Power-on time upon 2nd fault	—	—	◇
F9.34	Running time upon 2nd fault	—	—	◇
F9.37	Frequency upon 1st fault	—	—	◇
F9.38	Current upon 1st fault	—	—	◇
F9.39	Bus voltage upon 1st fault	—	—	◇
F9.40	X status upon 1st fault	—	—	◇
F9.41	The inverter temperature upon 1st fault	—	—	◇
F9.42	inverter status upon 1st fault	—	—	◇
F9.43	Power-on time upon 1st fault	—	—	◇
F9.44	Running time upon 1st fault	—	—	◇
F9.47	Fault protection action selection 1	Unit's digit (Motor overload, Err11) 0: Coast to stop 1: Stop according to the stop mode 2: Continue to run Ten's digit (Power input phase loss, Err12) Hundred's digit (Power output phase loss, Err13) Thousand's digit (External equipment fault, Err15) Ten thousand's digit (Communication fault, Err16)	00000	●
F9.48	Fault protection action selection 2	Unit's digit (Encoder fault, Err20) 0: Coast to stop Ten's digit (EEPROM read-write fault, Err21)	00000	●

<p>F9.49</p>	<p>Fault protection action selection 3</p>	<p>0: Coast to stop                      1: Stop according to the stop mode                      Hundred's digit: reserved                      Thousand's digit: reserved                      Ten thousand's digit :(Accumulative running time reached)                      Unit's digit (User-defined fault 1, Err27)                      0: Coast to stop                      1: Stop according to the stop mode                      2: Continue to run                      Ten's digit (User-defined fault 2, Err28)                      0: Coast to stop                      1: Stop according to the stop mode                      2: Continue to run                      Hundred's digit (Accumulative power-on time reached, Err29)                      0: Coast to stop                      1: Stop according to the stop mode                      2: Continue to run                      Thousand's digit (Load becoming 0, Err30)                      0: Coast to stop                      1: Stop according to the stop mode                      2: Continue to run at 7% of rated motor frequency and resume to the set frequency if the load recovers                      Ten thousand's digit (PID feedback lost during running, Err31)                      0: Coast to stop                      1: Stop according to the stop mode                      2: Continue to run</p>		
<p>F9.50</p>	<p>Fault protection action selection 4</p>	<p>Unit's digit (Too large speed deviation,Err42)</p>	<p>00000</p>	<p>●</p>

		0: Coast to stop 1: Stop according to the stop mode 2: Continue to run		
F9.54	Frequency selection for continuing to run upon fault	0: Current running frequency 1: Set frequency 2: Frequency upper limit 3: Frequency lower limit 4: Backup frequency upon abnormality	0	●
F9.55	Backup frequency upon abnormality	60.0%~100.0% 100.0%: maximum frequency (F0.10)	100.0%	●
F9.59	Action selection at instantaneous power failure	0: Invalid 1: Decelerate 2: Decelerate to stop	0	●
F9.60	Action pause judging voltage at instantaneous power failure	80.0%~100.0%	90.0%	●
F9.61	Voltage rally judging time at instantaneous power failure	0.00s~100.00s	0.50s	●
F9.62	Action judging voltage at instantaneous power failure	60.0%~100.0% (standard bus voltage)	80.0%	●
F9.63	Protection upon load becoming 0	0: Disabled 1: Enabled	0	●
F9.64	Detection level of load becoming 0	0.0~100.0%	10.0%	●
F9.65	Detection time of load becoming 0	0.0~60.0s	1.0s	●
F9.67	Over-speed detection value	0.0%~50.0% (maximum frequency)	20.0%	●
F9.68	Over-speed detection time	0.0s~60.0s	5.0s	●
F9.69	Detection value of too large speed deviation	0.0%~50.0% (maximum frequency)	20.0%	●
F9.70	Detection time of too large speed deviation	0.0s~60.0s	0.0s	●

Function code	Parameter Name	Setting range	Default	Property
Group FA: PID Function Parameters				
FA.00	PID setting source	0: FA.01 1: AI1 2: AI2 3: AI3 4: Pulse setting (DI5) 5: Communication setting 6: Multi-reference	0	●
FA.01	PID digital setting	0.0%~100.0%	50.0%	●
FA.02	PID feedback source	0: AI1 1: AI2 2: AI3 3: AI1-AI2 4: Pulse setting (X5) 5: Communication setting 6: AI1 + AI2	0	●
		7: MAX (AI1, AI2) 8: MIN (AI1, AI2)		
FA.03	PID action direction	0: Forward action 1: Reverse action	0	●
FA.04	PID setting feedback range	0~65535	1000	●
FA.05	Proportional gain Kp1	0.0~100.0	20.0	●
FA.06	Integral time Ti1	0.01s~10.00s	2.00s	●
FA.07	Differential time Td1	0.000s~10.000s	0.000s	●
FA.08	Cut-off frequency of PID reverse rotation	0.00 to maximum frequency	0.00Hz	●
FA.09	PID deviation limit	0.0%~100.0%	0.0%	●
FA.10	PID differential limit	0.00%~100.00%	0.10%	●
FA.11	PID setting change time	0.00~650.00s	0.00s	●
FA.12	PID feedback filter time	0.00~60.00s	0.00s	●
FA.13	PID output filter time	0.00~60.00s	0.00s	●
FA.15	Proportional gain Kp2	0.0~100.0	20.0	●
FA.16	Integral time Ti2	0.01s~10.00s	2.00s	●
FA.17	Differential time Td2	0.000s~10.000s	0.000s	●
FA.18	PID parameter switchover condition	0: No switchover 1: Switchover via X 2: Automatic switchover based on deviation	0	●
FA.19	PID parameter switchover deviation 1	0.0%~FA.20	20.0%	●
FA.20	PID parameter switchover deviation 2	FA.19~100.0%	80.0%	●

Function code	Parameter Name	Setting range	Default	Property
FA.21	PID initial value	0.0%~100.0%	0.0%	●
FA.22	PID initial value holding time	0.00~650.00s	0.00s	●
FA.23	Maximum deviation between two PID outputs in forward direction	0.00%~100.00%	1.00%	●
FA.24	Maximum deviation between two PID outputs in reverse direction	0.00%~100.00%	1.00%	●
FA.25	PID integral property	Unit's digit (Integral separated) 0: Invalid 1: Valid Ten's digit (Whether to stop integral operation when the output reaches the limit) 0: Continue integral operation 1: Stop integral operation	00	●
FA.26	Detection value of PID feedback loss	0.0%: Not judging feedback loss 0.1% - 100.0%	0.0%	●
FA.27	Detection time of PID feedback loss	0.0s~20.0s	0.0s	●
FA.28	PID operation at stop	0: No PID operation at stop 1: PID operation at stop	0	●



Function code	Parameter Name	Setting range	Default	Property
Group Fb: Swing Frequency, Fixed Length, Count and Torque Control and Restricting Parameters				
Fb.00	Swing frequency setting mode	0: Relative to the central frequency 1: Relative to the maximum frequency	0	●
Fb.01	Swing frequency amplitude	0.0%~100.0%	0.0%	●
Fb.02	Jump frequency amplitude	0.0%~50.0%	0.0%	●
Fb.03	Swing frequency cycle	0.1s~3000.0s	10.0s	●
Fb.04	Triangular wave rising time coefficient	0.1%~100.0%	50.0%	●
Fb.05	Set length	0m~65535m	1000m	●
Fb.06	Actual length	0m~65535m	0m	●
Fb.07	Number of pulses per meter	0.1~6553.5	100.0	●
Fb.08	Set count value	1~65535	1000	●
Fb.09	Designated count value	1~65535	1000	●
Fb.10	Speed/Torque control selection	0: Speed control 1: Torque control	0	○
Fb.11	Torque setting source in torque control	0: Digital setting (Fb.12) 1: AI1 2: AI2 3: AI3 4: Pulse setting (DI5) 5: Communication setting 6: MIN (AI1, AI2) 7: MAX (AI1, AI2) (Full range of values 1-7 corresponds to the digital setting of Fb.12).	0	○
Fb.12	Torque digital setting in torque control	-200.0%~200.0%	150.0%	●
Fb.13	Forward maximum frequency in torque control	0.00Hz to maximum frequency	50.00Hz	●
Fb.14	Reverse maximum frequency in torque control	0.00Hz to maximum frequency	50.00Hz	●
Fb.15	Acceleration time in torque control	0.00s~65000s	0.00s	●
Fb.16	Deceleration time in torque control	0.00s~65000s	0.00s	●

Function code	Parameter Name	Setting range	Default	Property
Group FC: Multi-Reference and Simple PLC Function Parameters				
FC.00	Reference 0	-100.0%~100.0%	0.0%	●
FC.01	Reference 1	-100.0%~100.0%	0.0%	●
FC.02	Reference 2	-100.0%~100.0%	0.0%	●
FC.03	Reference 3	-100.0%~100.0%	0.0%	●
FC.04	Reference 4	-100.0%~100.0%	0.0%	●
FC.05	Reference 5	-100.0%~100.0%	0.0%	●
FC.06	Reference 6	-100.0%~100.0%	0.0%	●
FC.07	Reference 7	-100.0%~100.0%	0.0%	●
FC.08	Reference 8	-100.0%~100.0%	0.0%	●
FC.09	Reference 9	-100.0%~100.0%	0.0%	●
FC.10	Reference10	-100.0%~100.0%	0.0%	●
FC.11	Reference11	-100.0%~100.0%	0.0%	●
FC.12	Reference12	-100.0%~100.0%	0.0%	●
FC.13	Reference13	-100.0%~100.0%	0.0%	●
FC.14	Reference14	-100.0%~100.0%	0.0%	●
FC.15	Reference15	-100.0%~100.0%	0.0%	●
FC.16	Simple PLC running mode	0: Stop after the inverter runs one cycle 1: Keep final values after the inverter runs one cycle 2: Repeat after the inverter runs one cycle	0	●
FC.17	Simple PLC retentive selection	Unit's digit (Retentive upon power failure) 0: No 1: Yes Ten's digit (Retentive upon stop) 0: No 1: Yes	00	●
FC.18	Running time of simple PLC reference 0	0.0s(h)~6553.5s(h)	0.0s (h)	●
FC.19	Acceleration/deceleration time of simple PLC reference 0	0~3	0	●
FC.20	Running time of simple PLC reference 1	0.0s(h)~6553.5s(h)	0.0s (h)	●
FC.21	Acceleration/deceleration time of simple PLC reference 1	0~3	0	●
FC.22	Running time of simple PLC reference 2	0.0s(h)~6553.5s(h)	0.0s (h)	●
FC.23	Acceleration/deceleration time of simple PLC reference 2	0~3	0	●

Function code	Parameter Name	Setting range	Default	Property
FC.24	Running time of simple PLC reference 3	0.0s(h)~6553.5s(h)	0.0s (h)	●
FC.25	Acceleration/deceleration time of simple PLC reference 3	0~3	0	●
FC.26	Running time of simple PLC reference 4	0.0s(h)~6553.5s(h)	0.0s (h)	●
FC.27	Acceleration/deceleration time of simple PLC reference 4	0~3		●
FC.28	Running time of simple PLC reference 5	0.0s(h)~6553.5s(h)	0.0s (h)	●
FC.29	Acceleration/deceleration time of simple PLC reference 5	0~3	0	●
FC.30	Running time of simple PLC reference 6	0.0s(h)~6553.5s(h)	0.0s (h)	●
FC.31	Acceleration/deceleration time of simple PLC reference 6	0~3	0	●
FC.32	Running time of simple PLC reference 7	0.0s(h)~6553.5s(h)	0.0s (h)	●
FC.33	Acceleration/deceleration time of simple PLC reference 7	0~3	0	●
FC.34	Running time of simple PLC reference 8	0.0s(h)~6553.5s(h)	0.0s (h)	●
FC.35	Acceleration/deceleration time of simple PLC reference 8	0~3	0	●
FC.36	Running time of simple PLC reference 9	0.0s(h)~6553.5s(h)	0.0s (h)	●
FC.37	Acceleration/deceleration time of simple PLC reference 9	0~3	0	●
FC.38	Running time of simple PLC reference 10	0.0s(h)~6553.5s(h)	0.0s (h)	●
FC.39	Acceleration/deceleration time of simple PLC reference 10	0~3	0	●
FC.40	Running time of simple PLC reference 11	0.0s(h)~6553.5s(h))	0.0s (h)	●
FC.41	Acceleration/deceleration time of simple PLC reference 11	0~3	0	●
FC.42	Running time of simple PLC reference 12	0.0s(h)~6553.5s(h)	0.0s (h)	●

Function code	Parameter Name	Setting range	Default	Property
FC.43	Acceleration/deceleration time of simple PLC reference 12	0~3	0	●
FC.44	Running time of simple PLC reference 13	0.0s(h)~6553.5s(h)	0.0s (h)	●
FC.45	Acceleration/deceleration time of simple PLC reference 13	0~3	0	●
FC.46	Running time of simple PLC reference 14	0.0s(h)~6553.5s(h)	0.0s (h)	●
FC.47	Acceleration/deceleration time of simple PLC reference 14	0~3	0	●
FC.48	Running time of simple PLC reference 15	0.0s(h)~6553.5s(h)	0.0s (h)	●
FC.49	Acceleration/deceleration time of simple PLC reference 15	0~3	0	●
FC.50	Time unit of simple PLC running	0:s 1:h	0	●
FC.51	Reference 0 source	1: AI1 2: AI2 3: AI3 4: Pulse setting 5: PID 6: Set by preset frequency (F0.08), modified via terminal UP/DOWN	0	●
<b>Group Fd: Communication Parameters</b>				
Fd.00	Baud rate	0:300BPS 1:600BPS 2:1200BPS 3:2400BPS 4:4800BPS 5:9600BPS 6:19200BPS 7:38400BPS	5	●
Fd.01	Data format	0: No check, data format <8,N,2> 1: Even parity check, data format <8,E,1> 2: Upper limit, data format <8,N,1>	0	●
Fd.02	Local address	1~247 0: Broadcast address	1	●

Function code	Parameter Name	Setting range	Default	Property
Fd.03	Response delay	0ms~20ms	2	●
Fd.04	Communication timeout	0.0 (invalid) ,0.1s~60.0s	0.0	●
Fd.05	Modbus protocol selection and PROFIBUS-DP data format	Unit's digit: MODBUS 0:Non-standard Modbus protocol 1:Standard Modbus protocol	1	●
Fd.06	Communication reading current resolution	0:0.01A 1:0.1A	0	●
Group FE:Quick Menu Parameters				
FE.00	Quick Menu 0	F0.00~FF.xx P0.00~P1.xx H0.00~H0.xx	F0.01	●
FE.01	Quick Menu 1		F0.02	●
FE.02	Quick Menu 2		F0.03	●
FE.03	Quick Menu 3		F0.07	●
FE.04	Quick Menu 4		F0.08	●
FE.05	Quick Menu 5		F0.17	●
FE.06	Quick Menu 6		F0.18	●
FE.07	Quick Menu 7		F3.00	●
FE.08	Quick Menu8		F3.01	●
FE.09	Quick Menu 9		F4.00	●
FE.10	Quick Menu 10		F4.01	●
FE.11	Quick Menu 11		F4.02	●
FE.12	Quick Menu 12		F5.04	●
FE.13	Quick Menu 13		F5.07	●
FE.14	Quick Menu 14		F6.00	●
FE.15	Quick Menu 15		F6.10	●
FE.16	Quick Menu 16		F0.00	●
FE.17	Quick Menu 17		F0.00	●
FE.18	Quick Menu 18		F0.00	●
FE.19	Quick Menu 19		F0.00	●
FE.20	Quick Menu 20		F0.00	●
FE.21	Quick Menu 21		F0.00	●
FE.22	Quick Menu 22		F0.00	●
FE.23	Quick Menu 23		F0.00	●
FE.24	Quick Menu 24		F0.00	●
FE.25	Quick Menu 25		F0.00	●
FE.26	Quick Menu 26		F0.00	●
FE.27	Quick Menu 27		F0.00	●
FE.28	Quick Menu 28		F0.00	●
FE.29	Quick Menu 29	F0.00	●	

Function code	Parameter Name	Setting range	Default	Property
Group P0: Analog Four points offset Parameters				
P0.00	AI curve 4 minimum input	-10.00V~P0.02	0.00V	●
P0.01	Corresponding setting of AI curve 4 minimum input	-100.0%~+100.0%	0.0%	●
P0.02	AI curve 4 inflexion 1 input	P0.00~P0.04	3.00V	●
P0.03	Corresponding setting of AI curve 4 inflexion 1 input	-100.0%~+100.0%	30.0%	●
P0.04	AI curve 4 inflexion	P0.02~P0.06	6.00V	●
P0.05	Corresponding setting of AI curve 4 inflexion 1 input	-100.0%~+100.0%	60.0%	●
P0.06	AI curve 4 maximum input	P0.06~+10.00V	10.00V	●
P0.07	Corresponding setting of AI curve 4 maximum input	-100.0%~+100.0%	100.0%	●
P0.08	AI curve 5 minimum input	-10.00V~P0.10	-10.00V	●
P0.09	Corresponding setting of AI curve 5 minimum input	-100.0%~+100.0%	-100.0%	●
P0.10	AI curve 5 inflexion 1 input	P0.08~P0.12	-3.00V	●
P0.11	Corresponding setting of AI curve 5 inflexion 1 input	-100.0%~+100.0%	-30.0%	●
P0.12	AI curve 5 inflexion 1 input	P0.10~P0.14	3.00V	●
P0.13	Corresponding setting of AI curve 5 inflexion 1 input	-100.0%~+100.0%	30.0%	●
P0.14	AI curve 5 maximum input	P0.12~+10.00V	10.00V	●
P0.15	Corresponding setting of AI curve 5 maximum input	-100.0%~+100.0%	100.0%	●
P0.24	Jump point of AI1 input corresponding setting	-100.0%~100.0%	0.0%	●
P0.25	Jump amplitude of AI1 input corresponding setting	0.0%~100.0%	0.5%	●

Function code	Parameter Name	Setting range	Default	Property
P0.26	Jump point of AI2 input corresponding setting	-100.0%~100.0%	0.0%	●
P0.27	Jump amplitude of AI2 input corresponding setting	0.0%~100.0%	0.5%	●
P0.28	Jump point of AI3 input corresponding setting	-100.0%~100.0%	0.0%	●
P0.29	Jump amplitude of AI3 input corresponding	0.0%~100.0%	0.5%	●
<b>Group P1: AI/AO Correction Parameters</b>				
P1.00	AI1 measured voltage 1	0.500V~4.000V	Factory corrected	●
P1.01	AI1 displayed voltage 1	0.500V~4.000V	Factory corrected	●
P1.02	AI1 measured voltage 2	6.000V~9.999V	Factory corrected	●
P1.03	AI1 displayed voltage 2	6.000V~9.999V	Factory corrected	●
P1.04	AI2 measured voltage 1	0.500V~4.000V	Factory corrected	●
P1.05	AI2 displayed voltage 1	0.500V~4.000V	Factory corrected	●
P1.06	AI2 measured voltage 2	6.000V~9.999V	Factory corrected	●
P1.07	AI2 displayed voltage 2	6.000V~9.999V	Factory corrected	●
P1.08	AI3 measured voltage 1	0.500V~4.000V	Factory corrected	●
P1.09	AI3 displayed voltage 1	0.500V~4.000V	Factory corrected	●
P1.10	AI3 measured voltage 2	6.000V~9.999V	Factory corrected	●
P1.11	AI3 displayed voltage 2	6.000V~9.999V	Factory corrected	●
P1.12	AO1 target voltage 1	0.500V~4.000V	Factory corrected	●
P1.13	AO1 measured voltage 1	0.500V~4.000V	Factory corrected	●
P1.14	AO1 target voltage 2	6.000V~9.999V	Factory corrected	●
P1.15	AO1 measured voltage 2	6.000V~9.999V	Factory corrected	●
P1.16	AO2 target voltage 1	0.500V~4.000V	Factory corrected	●
P1.17	AO2 measured voltage 1	0.500V~4.000V	Factory corrected	●

P1.18	AO2 target voltage 2	6.000V~9.999V	Factory corrected	●
P1.19	AO2 measured voltage 2	6.000V~9.999V	Factory corrected	●
P1.20	AI1 filtering dead zone	0~255	0	●
P1.21	AI2 filtering dead zone	0~255	0	●
P1.22	AI3 filtering dead zone	0~255	66	●

Function Code	Parameter Name	Min. Unit
Group H0: Standard Monitoring Parameters		
H0.00	Running frequency (Hz)	0.01Hz
H0.01	Set frequency (Hz)	0.01Hz
H0.02	Output current(A)	0.01A
H0.03	Output voltage (V)	1V
H0.04	Output power (kW)	0.1kW
H0.05	Output torque (%)	0.1%
H0.06	Bus voltage (V)	0.1V
H0.07	X input state1	1
H0.08	X input state 2	1
H0.09	DO output state	1
H0.10	AI1 voltage (V)	0.01V
H0.11	AI2 voltage (V)	0.01V
H0.12	AI3 voltage (V)	0.01V
Function Code	Parameter Name	Min. Unit
H0.13	Input pulse frequency (kHz)	0.01kHz
H0.14	PID setting	1
H0.15	PID feedback	1
H0.16	PID output	1
H0.17	Load speed	1
H0.18	Main frequency	0.01Hz
H0.19	Auxiliary frequency	0.01Hz
H0.20	Feedback speed	0.1Hz
H0.21	Count value	1
H0.22	Length value	1
H0.23	Linear speed	1m/Min
H0.24	Accumulative power-on time	1Min
H0.25	Accumulative running time	0.1Min
H0.26	Motor overload count	0.1%
H0.27	Motor current percentage	0.1%
H0.28	Remaining operating time	0.1Min



H0.29	PLC stage	1
H0.30	Communication setting value	0.01%
H0.31	AI1 voltage before correction	0.01V
H0.32	AI2 voltage before correction	0.01V
H0.33	AI3 voltage before correction	0.01V
H0.34	inverter overload count	0.1%
H0.35	inverter current percentage	0.1%

## Chapter7 Description of Function Codes

### Group F0 :Basic Parameters

F0.00	G/P type	Range:1~2	Default:1
-------	----------	-----------	-----------

1: G type (constant torque load)

2: P type (variable torque load e.g. Fan and pump)

F0.01	Motor control mode	Range:0~2	Default:2
-------	--------------------	-----------	-----------

0: Sensorless flux vector control (SFVC)

It indicates open-loop vector control, and is applicable to high-performance control applications such as machine tool, centrifuge, wire drawing machine and injection moulding machine. One inverter can operate only one motor.

1: Closed-loop vector control (CLVC)

It is applicable to high-accuracy speed control or torque control applications such as high-speed paper making machine, crane and elevator. One inverter can operate only one motor. An encoder must be installed at the motor side, and a PG card matching the encoder must be installed at the inverter side.

2: Voltage/Frequency (V/F) control

It is applicable to applications with low load requirements or applications where one inverter operates multiple motors, such as fan and pump.

F0.02	Command source options	Range:0~2	Default:0
-------	------------------------	-----------	-----------

0: Operation panel control

Commands are given by pressing keys “RUN,STOP”on the operation panel.

1: Terminal control

Commands are given by means of multifunctional input terminals with functions such as “FWD, REV, JOGF, and JOGR”.

2: Communication control

Commands are given from host computer.

F0.03	Main frequency(X) source selection	Range:0~13	Default:4
-------	------------------------------------	------------	-----------

0: Digital setting (non-retentive at power failure)

The initial value of the set frequency is the value of F0.08 (Preset frequency). You can change the set frequency by pressing  $\Delta$ 、V on the operation panel (or using the UP/DOWN function of input terminals).

When the inverter is powered on again after power failure, the set frequency reverts to the value of F0.08.

1: Digital setting (retentive at power failure)

Basic operations are the same as "0: Digital setting" .

The only difference is that when the inverter is powered on again after power failure, the set frequency is the value memorized at the moment of the last power failure.

Note: The hidden parameters set down by F0.20 cleared or unclear 0, factory default is cleared down.

2: AI1 (0–10 V voltage input)

3: AI2 (0–10 V voltage input or 4–20 mA current input, determined by jumper )

4: AI3 (0–10 V voltage input)

The frequency is set by analog input.

5: Pulse setting (X5)

The frequency is set by X5 (high-speed pulse). The signal specification of pulse setting is

9–30 V (voltage range) and 0–100 kHz (frequency range). The corresponding value 100% of pulse setting corresponds to the value of F0.10 (Maximum frequency).

6: Multi-reference

In multi-reference mode, combinations of different X terminal states correspond to different set frequencies. The JT580 supports a maximum of 16 speeds implemented by 16 state combinations of four X terminals (allocated with functions 12 to 15) in Group FC. The multiple references indicate percentages of the value of F0.10 (Maximum frequency).

If a X terminal is used for the multi-reference function, you need to perform related setting in group F2.

7: Simple PLC

When the simple programmable logic controller (PLC) mode is used as the frequency source, the running frequency of the inverter can be switched over among the 16 frequency references. You can set the holding time and acceleration/deceleration time of the 16 frequency references. For details, refer to the descriptions of Group FC.

8: PID

The output of PID control is used as the running frequency. PID control is generally used in on-site closed-loop control, such as constant pressure closed-loop control and constant tension closed-loop control. When applying PID as the frequency source, you need to set parameters of PID function in group FA.

9: Communication setting

The frequency is set by means of communication. In other conditions, data is given by the host computer through the communication address 0x1000. The data format is -100.00% to 100.00%. 100.00% corresponds to the value of F0.10 (Maximum frequency).

10: AI1+AI2

11: AI1-AI2

12: max(AI1, AI2)

13: min(AI1, AI2)

F0.04	Auxiliary frequency(Y) given ways	Range:0~9	Default:0
-------	-----------------------------------	-----------	-----------

When used as an independent frequency input channel (frequency source switched over from X to Y), the auxiliary frequency source Y is used in the same way as the main frequency source X (refer to F0.03).

When the auxiliary frequency source is used for operation (frequency source is "X and Y operation"), pay attention to the following aspects:

1) If the auxiliary frequency source Y is digital setting, the preset frequency (F0.08) does not take effect. You can directly adjust the set main frequency by pressing keys  $\wedge$ 、 $\vee$  on the operation panel (or using the UP/DOWN function of input terminals).

2) If the auxiliary frequency source is analog input (AI1, AI2 and AI3) or pulse setting, 100% of the input corresponds to the range of the auxiliary frequency Y (set in F0.05 and F0.06).

3) If the auxiliary frequency source is pulse setting, it is similar to analog input.

The main frequency source X and auxiliary frequency source Y must not use the same channel. That is, F0.03 and F0.04 cannot be set to the same value.

F0.05	Auxiliary speed range selection	Range:0~1	Default:0
F0.06	Auxiliary speed range	Range:0~150	Default:100%

If X and Y operation is used, F0.05 and F0.06 are used to set the adjustment range of the auxiliary frequency source. You can set the auxiliary frequency to be relative to either maximum frequency or main frequency X. If relative to main frequency X, the setting range of the auxiliary frequency varies according to the main frequency X.

F0.07	Frequency source selection	Range:0~34	Default:0
-------	----------------------------	------------	-----------

Ten's digit	Unit's digit
0: X+Y	0: Main frequency source
1: X-Y	1: Main frequency (X) and auxiliary frequency(Y) operation(operation relationship determined by ten's digit)
2: Maximum	2: Switch over between main frequency and auxiliary frequency
3: Minimum	3: Switch over between main frequency and "main frequency and auxiliary frequency operation"
	4: Switch over between auxiliary frequency and "main frequency and auxiliary frequency operation"

It is used to select the frequency setting channel. If the frequency source involves X and Y operation, you can set the frequency offset in F0.21 for superposition to the X and Y operation result, flexibly satisfying various requirements.

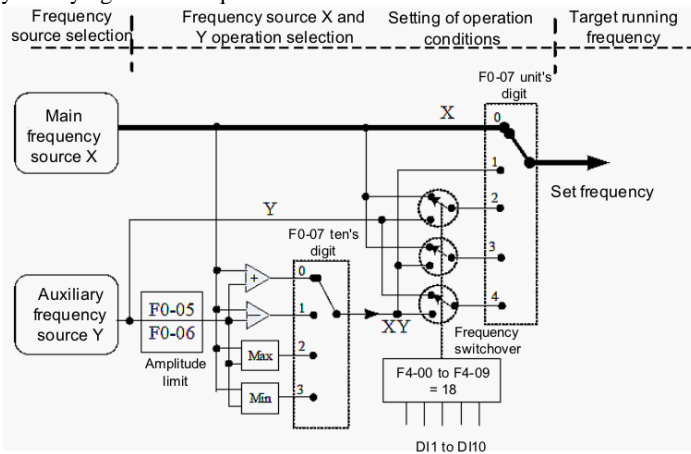

Figure7.1 Frequency setting based on main frequency source X and auxiliary frequency source Y

F0.08	Digital frequency	Range:0.00Hz~maximum frequency(valid when frequency source is digital setting)	Default:50.00Hz
-------	-------------------	--	-----------------

If the frequency source is digital setting or terminal UP/DOWN, the value of this parameter is the initial frequency of the inverter (digital setting).

F0.09	Rotation direction	Range:0~1	Default:0
-------	--------------------	-----------	-----------

- 0: Same direction
- 1: Reverse direction

You can change the rotation direction of the motor just by modifying this parameter without changing the motor wiring. Modifying this parameter is equivalent to exchanging any two of the motor's U, V, W wires.

F0.10	Maximum frequency	Range:50.00Hz~320.00Hz	Default:50.00Hz
-------	-------------------	------------------------	-----------------

When the frequency source is AI, pulse setting (X5), or multi-reference, 100% of the input corresponds to the value of this parameter.

F0.11	Source of frequency upper limit	Range:0~5	Default:0
-------	---------------------------------	-----------	-----------

It is used to set the source of the frequency upper limit, including digital setting (F0.12), AI,pulse setting or communication setting. If the frequency upper limit is set by means of

AI1,AI2, AI3, DI5 or communication, the setting is similar to that of the main frequency source X.For details, see the description of F0.03.

F0.12	Frequency upper limit	Range:lower limit (F0.14) ~maximum frequency (F0.10)	Default:50.00Hz
-------	-----------------------	--	-----------------

This parameter is used to set the frequency upper limit.

F0.13	Frequency upper limit offset	Range:0.00~maximum frequency	Default:0.00 Hz
-------	------------------------------	------------------------------	-----------------

If the source of the frequency upper limit is analog input or pulse setting, the final frequency upper limit is obtained by adding the offset in this parameter to the frequency upper limit set in F0.11.

F0.14	Frequency lower limit	Range:0.00~frequency upper limit	Default:0.00 Hz
-------	-----------------------	----------------------------------	-----------------

If the frequency reference is lower than the value of this parameter, the inverter can stop, run at the frequency lower limit, or run at zero speed, determined by F4.14.

F0.15	Carrier frequency	Range:0.5kHz ~16.0kHz	Default:Model Dependent
-------	-------------------	-----------------------	-------------------------

It is used to adjust the carrier frequency of the inverter, helping to reduce the motor noise, avoiding the resonance of the mechanical system, and reducing the leakage current to the earth and interference generated by the inverter.

If the carrier frequency is low, output current has high harmonics, and the power loss and temperature rise of the motor increase.

If the carrier frequency is high, power loss and temperature rise of the motor declines. However, the inverter has an increase in power loss, temperature rise and interference.

Adjusting the carrier frequency will exert influences on the aspects listed in the following table.

Table 7-1 Influences of carrier frequency adjustment

Carrier frequency	Low	High
Motor noise	Large	Small
Output current waveform	Bad	Good
Motor temperature rise	High	Low
AC drive temperature rise	Low	High
Leakage current	Small	Large
External radiation interference	Small	Large

The factory setting of carrier frequency varies with the inverter power. If you need to modify the carrier frequency, note that if the set carrier frequency is higher than factory setting, it will lead to an increase in temperature rise of the inverter's heatsink. In this case, you need to derate the inverter. Otherwise, the inverter may overheat and alarm.

F0.16	Carrier frequency adjustment with temperature	Range:0~1	Default:1
-------	---	-----------	-----------

0: No

1: Yes

It is used to set whether the carrier frequency is adjusted based on the temperature. The inverter automatically reduces the carrier frequency when detecting that the heatsink temperature is high. The inverter resumes the carrier frequency to the set value when the heatsink temperature becomes normal. This function reduces the overheat alarms.

F0.17	Acceleration time 1	Range:0.0s~6500.0s	Default:Model Dependent
F0.18	Deceleration time 1	Range:0.0s~6500.0s	Default:Model Dependent

Acceleration time indicates the time required by the inverter to accelerate from 0 Hz to "Acceleration/Deceleration base frequency" (F0.21), that is, t1 in Figure 6.2. Deceleration time indicates the time required by the AC drive to decelerate from "Acceleration/Deceleration base frequency" (F0.21) to 0 Hz, that is, t2 in Figure 6.2.

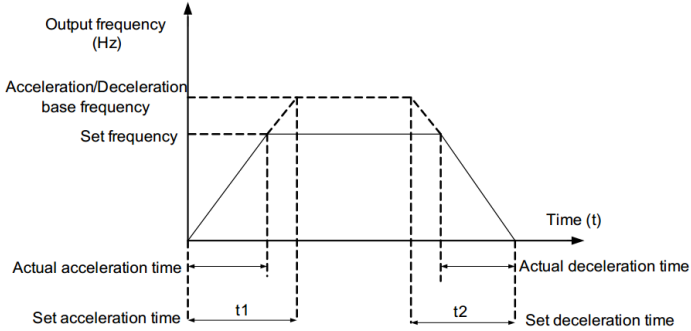

Figure7.2 Acceleration/Deceleration time

The JT580 provides totally four groups of acceleration/deceleration time for selection. You can perform switchover by using a X terminal.

- Group 1: F0.17, F0.18
- Group 2: F4.03, F4.04
- Group 3: F4.05, F4.06
- Group 4: F4.07, F4.08

F0.19	Frequency offset of auxiliary frequency source for X and Y operation	Range:0.00Hz~maximum frequency	Default:0.00Hz
-------	--	--------------------------------	----------------

F0.20	Digital set frequency attribute selection	Range:0~1	Default:0
-------	---	-----------	-----------

Thousand's digit	Hundred's digit	Ten's digit	Units' digit
terminal UP/DN rate 0: frequency rate.F2.12 is rate, the unit for Hz/s 1: integral rate.F2.12 is time, the unit is "s", F2.12 only one decimal of F2.12 IS effectively, the last two are ignored.	when stop the UP/DN effective choice 0: Valid 1: Invalid	the UP/DN and reversing choice when analog superposition 0: can the reversing 1: not the reversing	stop memory options 0: no. 1: memory

F0.21	Acceleration/Deceleration time base frequency	Range:0~2	Default:0
-------	---	-----------	-----------

- 0: Maximum frequency (F0.10)
- 1: Set frequency
- 2: 100 Hz

The acceleration/deceleration time indicates the time for the inverter to increase from 0 Hz to the frequency set in F0.21. If this parameter is set to 1, the acceleration/deceleration time is related to the set frequency. If the set frequency changes frequently, the motor's

acceleration/deceleration also changes.

F0.22	Base frequency for UP/DOWN modification during running	Range:0~1	Default:0
-------	--	-----------	-----------

- 0: Running frequency
- 1: Set frequency

This parameter is valid only when the frequency source is digital setting.

It is used to set the base frequency to be modified by using keys and or the terminal UP/DOWN function. If the running frequency and set frequency are different, there will be a large difference between the inverter's performance during the acceleration/deceleration process.

F0.23	User password	Range:0~65536	Default:0
-------	---------------	---------------	-----------

If it is set to any non-zero number, the password protection function is enabled. After a password has been set and taken effect, you must enter the correct password in order to enter the menu. If the entered password is incorrect you cannot view or modify parameters.

If F0.23 is set to 00000, the previously set user password is cleared, and the password protection function is disabled.

F0.24	Restore default settings	Range:0~501	Default:0
-------	--------------------------	-------------	-----------

- 1: Restore default settings except motor parameters

If F0.24 is set to 1, most function codes are restored to the default settings except motor parameters, frequency reference resolution, fault records, accumulative running time, accumulative power-on time and accumulative power consumption .

- 2: Clear records

If F0.24 is set to 2, the fault records, accumulative running time , accumulative power-on time and accumulative power consumption are cleared.

F0.25	Individualized parameter display property	Range:0~11	Default:00
-------	---	------------	------------

The setting of parameter display mode aims to facilitate you to view different types of parameters based on actual requirements. The JT580 provides the following three parameter display modes.

Unit's digit: User-defined parameter display selection.This mode displays only the parameters user needs. Up to 30 parameters set by the FE group.

Ten's digit: Non-factory value menu, and the user to modify the parameters, this mode displays only the user modified parameters.

Ten's digit	Unit's digit
0: Not display	0: Not display
1: Display	1: Display

Menu mode switch over by MK.

F0.26	Parameter modification property	Range:0~1	Default:0
-------	---------------------------------	-----------	-----------

- 0: Modifiable
- 1: Not modifiable

It is used to set whether the parameters are modifiable to avoid mal-function. If it is set to 0, all parameters are modifiable. If it is set to 1, all parameters can only be viewed.

### Group F1: Motor parameters

F1.00	Motor model	Range:0~1	Default:0
-------	-------------	-----------	-----------

- 0: Common asynchronous motor
- 1: Variable frequency asynchronous motor

F1.01	Motor rated power	Range:0.1kW~1000.0kW	Default:Model
-------	-------------------	----------------------	---------------

			dependent
F1.02	Motor rated voltage	Range:1V~2000V	Default:Model dependent
F1.03	Motor rated current	Range:0.01A~655.35A ( $\leq$ 55kW) 0.1A~6553.5A ( $>$ 55kW)	Default:Model dependent
F1.04	Motor rated frequency	Range:0.01Hz~maximum frequency	Default:Model dependent
F1.05	Motor nominal speed	Range:1rpm~65535rpm	Default:Model dependent

F1.06	Motor stator resistance	Range:0.001 $\Omega$ ~65.535 $\Omega$ ( $\leq$ 55kW) 0.0001 $\Omega$ ~6.5535 $\Omega$ ( $>$ 55kW)	Default:Model dependent
F1.07	Rotor resistance	Range:0.001 $\Omega$ ~65.535 $\Omega$ ( $\leq$ 55kW) 0.0001 $\Omega$ ~6.5535 $\Omega$ ( $>$ 55kW)	Default:Model dependent
F1.08	Leakage inductive reactance	Range: 0.01mH~655.35mH( $\leq$ 55kW) 0.001mH~65.535mH( $>$ 55kW)	Default:Model dependent
F1.09	Mutual inductive reactance	Range:0.1mH~6553.5mH( $\leq$ 55kW) 0.01mH~655.35mH( $>$ 55kW)	Default:Model dependent
F1.10	No-load current	Range:0.01A~655.35A ( $\leq$ 55kW) 0.1A~6553.5A ( $>$ 55kW)	Default:Model dependent

After the end of normal motor parameter identification, setting F1.06 ~ F1.10 will be updated. Change the motor rated power (F1.01) or motor rated voltage (F1.02), the drive will F1.06 ~ F1.10 parameter is set to the default standard motor parameters.

F1.27	Encoder pulses per revolution	Range:0~65535	Default:0
-------	-------------------------------	---------------	-----------

This parameter is used to set the pulses per revolution (PPR) of ABZ or UVW incremental encoder. In CLVC mode, the motor cannot run properly if this parameter is set incorrectly.

F1.30	A/B phase sequence of ABZ incremental encoder	Range:0~1	Default:0
-------	---	-----------	-----------

It is valid for both asynchronous motor and synchronous motor. The A/B phase sequence can be obtained through "Asynchronous motor complete auto-tuning" or "Synchronous motor no-load auto-tuning".

F1.37	The parameters self-identification	Range:0~2	Default:0
-------	------------------------------------	-----------	-----------

0: No operation, which prohibits self-identification parameters



1: static self identification, suitable for induction motor and the load is not easy to disengage, but not a complete self-identification of the occasion

Asynchronous machine standstill since the previous identification, you must set the correct motor type and motor nameplate parameters F1.00 ~ F1.05. Stationary self-identification, the drive can get F1.06 ~ F1.08 three parameters.

Action Description: Set the function code is 1, then press the RUN key, the drive will still self-identify.

2: complete self-identification

To ensure the dynamic control performance of the inverter, please choose the complete self-identification, and the motor must be separated from the load to keep the motor for the no-load condition. Complete self-identification process, the inverter will be stationary self identification, and then follow the acceleration time to accelerate to 80% F0.17 rated motor frequency, after a period of time, according to the deceleration time F0.18 deceleration stop and end self identification.

Asynchronous machine complete self-identification, the drive can get F1.06 ~ F1.10 five motor parameters, and the encoder AB phase sequence F1.30, vector control current loop PI parameters F5.13 ~ F5.16.

Action Description: Set the function code is 2, then press the RUN key, the drive will be a complete self-identification.

### Group F2:Input Terminal

JT580 series inverter have five multi-function input terminals X1 ~ X5 (X5 which can be used as high-speed pulse input), two analog input terminal AI1, AI2 (which can be used as a voltage input AI2, but also as a current input), a keyboard potentiometer.

F2.00	X1 function selection	Range:0~50	Default:1
F2.01	X2 function selection	Range:0~50	Default:4
F2.02	X3 function selection	Range:0~50	Default:9
F2.03	X4 function selection	Range:0~50	Default:12
F2.04	X5 function selection	Range:0~50	Default:13
F2.05	X6 function selection	Range:0~50	Default:0
F2.06	X7 function selection	Range:0~50	Default:0
F2.07	X8 function selection	Range:0~50	Default:0
F2.08	X9 function selection	Range:0~50	Default:0
F2.09	X10function selection	Range:0~50	Default:0

Set value	Function	Description
0	No function	
1	Forward RUN (FWD)	The terminal is used to control forward or reverse RUN of the inverter.
2	Reverse RUN (REV)	
3	Three-line control	The terminal determines three-line control of the inverter. For details, see the description of F2.11.
4	Forward JOG (FJOG)	FJOG indicates forward JOG running, while RJOG indicates reverse JOG running. The JOG frequency,acceleration time and deceleration time are described respectively in F4.00,F4.01,F4.02.
5	Reverse JOG (RJOG)	
6	Terminal UP	If the frequency is determined by external terminals, the terminals with the two functions are used as increment and decrement commands for frequency
7	Terminal DOWN	

		modification. When the frequency source is digital setting, they are used to adjust the frequency.
8	Coast to stop	The inverter blocks its output, the motor coasts to rest and is not controlled by the inverter.
9	Fault reset (RESET)	The terminal is used for fault reset function, the same as the function of RESET key on the operation panel.
10	RUN pause	The inverter decelerates to stop, but the running parameters are all memorized, such as PLC, swing frequency and PID parameters. After this function is disabled, the inverter resumes its status before stop.
11	Normally open (NO) input of external fault	If this terminal becomes ON, the inverter reports Err15 and performs the fault protection action. For more details, see the description of F9.47.
12	Multi-reference terminal 1	The setting of 16 speeds or 16 other references can be implemented through combinations of 16 states of these four terminals.
13	Multi-reference terminal 2	
14	Multi-reference terminal 3	
15	Multi-reference terminal 4	
16	Terminal 1 for acceleration/deceleration time selection	Totally four groups of acceleration/deceleration time can be selected through combinations of two states of these two terminals.
17	Terminal 2 for acceleration/deceleration time selection	
18	Frequency source switch over	The terminal is used to perform switchover between two frequency sources according to the setting in F0.07
19	UP and DOWN setting clear (terminal, operation panel)	If the frequency source is digital setting, the terminal is used to clear the modification by using the UP/DOWN function or the increment/decrement key on the operation panel, returning the set frequency to the value of F0.08.
20	Command source switch over keyboard	If the command source is set to terminal control (F0.02 = 1), this terminal is used to perform switchover between terminal control and operation panel control. If the command source is set to communication control (F0.02 = 2), this terminal is used to perform switchover between communication control and operation panel control.
21	Acceleration/Deceleration prohibited	It enables the inverter to maintain the current frequency output without being affected by external signals (except the STOP command).
22	PID pause	PID is invalid temporarily. The inverter maintains the current frequency output without supporting PID adjustment of frequency source.
23	PLC status reset	The terminal is used to restore the original status of PLC control for the inverter when PLC control is started again after a pause
24	Swing pause	The inverter outputs the central frequency, and the swing frequency function pauses
25	Counter input	This terminal is used to count pulses

26	Counter reset	This terminal is used to clear the counter status.
27	Length count input	This terminal is used to count the length
28	Length reset	This terminal is used to clear the length
29	Torque control prohibited	The inverter is prohibited from torque control and enters the speed control mode.
30	Pulse input (enabled only for X5)	X5 is used for pulse input.
32	Immediate DC braking	After this terminal becomes ON, the inverter directly switches over to the DC braking state.
33	Normally closed (NC) input of external fault	After this terminal becomes ON, the inverter reports Err15 and stops.
34	Frequency modification forbidden	After this terminal becomes ON, the inverter does not respond to any frequency modification.
35	Reverse PID action direction	After this terminal becomes ON, the PID action direction is reversed to the direction set in FA.03.
36	External STOP terminal 1	In operation panel mode, this terminal can be used to stop the inverter, equivalent to the function of the STOP key on the operation panel.
37	Command source switch over terminal	It is used to perform switchover between terminal control and communication control. If the command source is terminal control, the system will switch over to communication control after this terminal becomes ON.
38	PID integral pause	After this terminal becomes ON, the integral adjustment function pauses. However, the proportional and differentiation adjustment functions are still valid.
39	Switch over between main frequency source X and digital Frequency	After this terminal becomes ON, the frequency source X is replaced by the preset frequency set in F0.08.
40	Switch over between auxiliary frequency source Y and digital frequency	After this terminal is enabled, the frequency source Y is replaced by the preset frequency set in F0.08
41	Switch over between PID parameters	If the PID parameters switchover performed by means of DI terminal (FA.18 = 1), the PID parameters are FA.05 to FA.07 when the terminal becomes OFF; the PID parameters are FA.15 to FA.17 when this terminal becomes ON.
42	User-defined fault 1	If these two terminals become ON, the inverter reports Err27 and Err28 respectively, and performs fault protection actions based on the setting in F9.49.
43	User-defined fault 2	
44	Speed control/Torque control switchover	This terminal enables the inverter to switch over between speed control and torque control. When this terminal becomes OFF, the inverter runs in the mode set in Fb.10. When this terminal becomes ON, the inverter switches over to the other control mode.
45	Emergency stop	When this terminal becomes ON, the inverter stops within the shortest time. During the stop process, the current remains at the set current upper limit. This function is used to satisfy the requirement of stopping

		the inverter in emergency state.
46	External STOP terminal 2	In any control mode (operation panel, terminal or communication), it can be used to make the inverter decelerate to stop. In this case, the deceleration time is deceleration time 4.
47	Deceleration DC braking	When this terminal becomes ON, the inverter decelerates to the initial frequency of stop DC braking and then switches over to DC braking state.
48	Clear the current running time	When this terminal becomes ON, the inverter's current running time is cleared. This function must be supported by F4.42 and F4.53

Table 7-2 Multi-reference Setting

Multi-reference Setting					
multi-reference terminal 4	multi-reference terminal 3	multi-reference terminal 2	multi-reference terminal 1	Frequency setting	Corresponding parameter
OFF	OFF	OFF	OFF	Reference 0	FC.51
OFF	OFF	OFF	ON	Reference 1	FC.01
OFF	OFF	ON	OFF	Reference 2	FC.02
OFF	OFF	ON	ON	Reference 3	FC.03
OFF	ON	OFF	OFF	Reference 4	FC.04
OFF	ON	OFF	ON	Reference 5	FC.05
OFF	ON	ON	OFF	Reference 6	FC.06
OFF	ON	ON	ON	Reference 7	FC.07
ON	OFF	OFF	OFF	Reference 8	FC.08
ON	OFF	OFF	ON	Reference 9	FC.09
ON	OFF	ON	OFF	Reference 10	FC.10
ON	OFF	ON	ON	Reference 11	FC.11
ON	ON	OFF	OFF	Reference 12	FC.12
ON	ON	OFF	ON	Reference 13	FC.13
ON	ON	ON	OFF	Reference 14	FC.14
ON	ON	ON	ON	Reference 15	FC.15

Table 7-3 State combinations of two terminals for acceleration/deceleration time selection

Acceleration/Deceleration Time Selection			
acceleration/deceleration time terminal 2	Acceleration /deceleration time terminal 1	acceleration/deceleration time selection	Corresponding parameter
OFF	OFF	Acceleration time1	F0.17、 F0.18
OFF	ON	Acceleration time2	F4.03、 F4.04
ON	OFF	Acceleration time3	F4.05、 F4.06
ON	ON	Acceleration time4	F4.07、 F4.08

F2.10	X filter time	Range:0.000s~1.000s	Default:0.010s
-------	---------------	---------------------	----------------

It is used to set the software filter time of X terminal status. If X terminals are liable to interference and may cause malfunction, increase the value of this parameter to enhance the anti-interference capability. However, increase of X filter time will reduce the response of X terminals.

F2.11	Terminal command mode	Range:0~3	Default:0
-------	-----------------------	-----------	-----------

0: Two-line mode 1

It is the most commonly used two-line mode, in which the forward/reverse rotation of the motor is decided by X1 and X2.

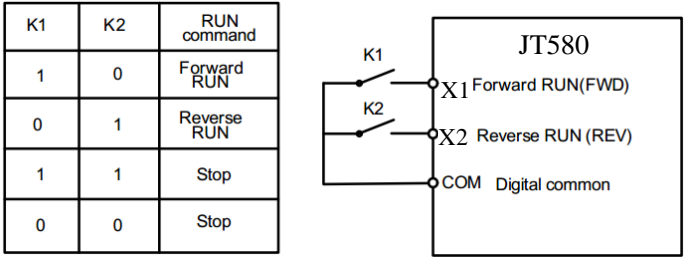

Figure7.3 Setting of two-line mode 1

1: Two-line mode 2

In this mode, DI1 is RUN enabled terminal, and DI2 determines the running direction.

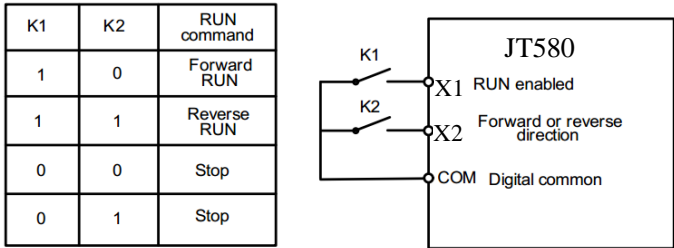

Figure7.4 Setting of two-line mode 2

As shown in the preceding Figure , if K1 is ON, the inverter instructs forward rotation when K2 is OFF, and instructs reverse rotation when K2 is ON. If K1 is OFF, the inverter stops.

2: Three-line mode 1

In this mode, X3 is RUN enabled terminal, and the direction is decided by X1 and X2.

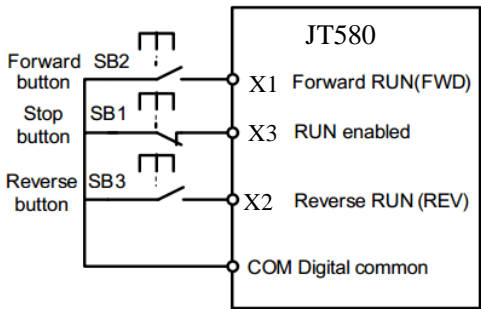

Figure7.5 Setting of three-line mode 1

As shown in the preceding Figure , if SB1 is ON, the inverter instructs forward rotation when SB2 is pressed to be ON and instructs reverse rotation when SB3 is pressed to be ON. The inverter stops immediately after SB1 becomes OFF. During normal startup and running,

SB1 must remain ON. The inverter's running state is determined by the final actions on SB1, SB2 and SB3.

3: Three-line mode 2

In this mode, X3 is RUN enabled terminal. The RUN command is given by X1 and the direction is decided by X2.

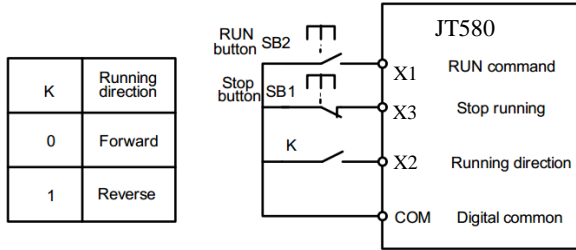

Figure7.6 Setting of three-line mode 2

As shown in the preceding Figure , if SB1 is ON, the inverter starts running when SB2 is pressed to be ON; the inverter instructs forward rotation when K is OFF and instructs reverse rotation when K is ON. The inverter stops immediately after SB1 becomes OFF. During normal startup and running, SB1 must remain ON. The inverter's running state is determined by the final actions of SB1, SB2 and K.

F2.12	Terminal UP/DOWN rate	Range:0.001~65.353	Default:1.000
-------	-----------------------	--------------------	---------------

It is used to adjust the rate of change of frequency when the frequency is adjusted by means of terminal UP/DOWN.

F2.13	AI1 filter time	Range:0.00s~10.00s	Default:0.10s
F2.14	AI2 filter time	Range:0.00s~10.00s	Default:0.10s
F2.15	AI3 filter time	Range:0.00s~10.00s	Default:0.10s

Definition analog input terminal AI1, AI2 and keyboard potentiometer filter time, the input signal filtering. Long filtering time, the anti-interference ability, but the slow response; filtering the fast response time is short, but weak anti-interference ability.

F2.16	AI curve 1 minimum input	Range:0.00V~F2.18	Default:0.20V
F2.17	Corresponding setting of AI curve 1 minimum input	Range:-100.0%~100.0%	Default:0.0%
F2.18	AI curve 1 maximum input	Range:F2.16~+10.00V	Default:10.00V
F2.19	Corresponding setting of AI curve 1 maximum input	Range:-100.0%~100.0%	Default:100.0%

These parameters are used to define the relationship between the analog input voltage and the corresponding setting. When the analog input voltage exceeds the maximum value (F2.16), the maximum value is used. When the analog input voltage is less than the minimum value (F2.18), the value set in F2.34 (Setting for AI less than minimum input) is used.

When the analog input is current input, 1 mA current corresponds to 0.5 V voltage. In different applications, 100% of analog input corresponds to different nominal values. For details, refer to the description of different applications. Two typical setting examples are shown in the following Figure .

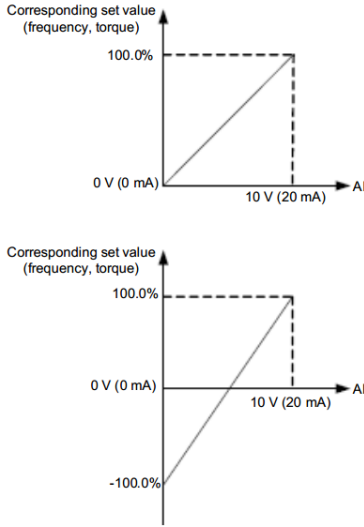

Figure7.7 Corresponding relationship between analog input and set values

F2.20	AI curve 2 minimum input	Range:0.00V~F2.22	Default:0.20V
F2.21	Corresponding setting of AI curve 2 minimum input	Range:-100.0%~+100.0%	Default:0.0%
F2.22	AI curve 2 maximum input	Range:F2.20~+10.00V	Default:10.00V
F2.23	Corresponding setting of AI curve 2 maximum input	Range:-100.0%~+100.0%	Default:100.0%
F2.24	AI curve 3 minimum input	Range:0.00V~F2.26	Default:0.20V
F2.25	Corresponding setting of AI curve 3 minimum input	Range:-100.0%~+100.0%	Default:0.0%
F2.26	AI curve 3 maximum input	Range:F2.24~+10.00V	Default:10.00V
F2.27	Corresponding setting of AI curve 3 maximum input	Range:-100.0%~+100.0%	Default:100.0%

Please refer to the curve 1 when use 2,3 curve function.

F2.28	PULSE minimum input	Range:0.00kHz~F2.30	Default:0.00kHz
F2.29	Corresponding setting of PULSE minimum input	Range:-100.0%~100.0%	Default:0.0%
F2.30	PULSE maximum input	Range:F2.28~100.00kHz	Default:50.00kHz
F2.31	Corresponding setting of PULSE maximum input	Range:-100.0%~100.0%	Default:100.0%

This group function code is used to set the relationship between the pulse frequency and the corresponding set X5 between. Pulse frequency inverter can only enter through X5 channel.

F2.32	PULSE filter time	Range:0.00s~10.00s	Default:0.10s
-------	-------------------	--------------------	---------------

PULSE input filtering time is defined on the input signal filtering. Long filtering time the strong anti-interference ability, but the corresponding slowdowns; filtering the fast response

time is short, but immunity is weakened.

F2.33	AI curve selection	Range:000~555	Default:321
-------	--------------------	---------------	-------------

The unit's digit, ten's digit and hundred's digit of this parameter are respectively used to select the corresponding curve of AI1, AI2 and AI3. Any of the five curves can be selected for AI1, AI2 and AI3.

Hundred's digit(AI3curve selection)	Ten's digit (AI2 curve selection)	Unit's digit (AI1 curve selection)
1:Curve 1:F2.16~F2.19	1:Curve 1:F2.16~F2.19	1:Curve 1:F2.16~F2.19
2:Curve 2:F2.20~F2.23	2:Curve2:F2.20~F2.23	2:Curve2:F2.20~F2.23
3:Curve 3:F2.24~F2.27	3:Curve3:F2.24~F2.27	3:Curve3:F2.24~F2.27
4:Curve 4:P0.00~P0.07	4:Curve4:P0.00~P0.07	4:Curve4:P0.00~P0.07
5:Curve 5:P0.08~P0.15	5:Curve5:P0.08~P0.15	5:Curve5:P0.08~P0.15

F2.34	Setting for AI less than minimum input	Range:000~111	Default:000
-------	--	---------------	-------------

This parameter is used to determine the corresponding setting when the analog input voltage is less than the minimum value. The unit's digit, ten's digit and hundred's digit of this parameter respectively correspond to the setting for AI2, AI2 and AI3.

If the value of a certain digit is 0, when analog input voltage is less than the minimum input, the corresponding setting of the minimum input (F2.17,F2.21,F2.25) is used.

If the value of a certain digit is 1, when analog input voltage is less than the minimum input, the corresponding value of this analog input is 0.0%.

F2.35	X1 delay time	Range:0.0s~3600.0s	Default:0.0s
F2.36	X2 delay time	Range:0.0s~3600.0s	Default:0.0s
F2.37	X3 delay time	Range:0.0s~3600.0s	Default:0.0s

These parameters are used to set the delay time of the inverter when the status of X terminals changes.Currently, only X1, X2 and X3 support the delay time function.

F2.38	X valid mode selection	Range:00000~11111	Default:00000
-------	------------------------	-------------------	---------------

0: High level valid

The X terminal is valid when being connected with COM, and invalid when being disconnected from COM.

1: Low level valid

The X terminal is invalid when being connected with COM, and invalid when being disconnected from COM.

Ten thousand's digit	Thousand's digit	Hundred's digit	Ten's digit	Unit's digit
X5	X4	X3	X2	X1

### Group F3: Output Terminals

JT580 series inverter comes standard with two digital output terminal Y1, Y2 (Y2 which can be used as high-speed pulse output DO), 2 relay outputs R, E, 2 analog outputs AO1, AO2 (can be selected as the current output).

F3.00	Y2/DO terminal output mode	Range:0~1	Default:1
-------	----------------------------	-----------	-----------

Y2 / DO terminal is re-programmable terminals, can be used as high-speed pulse output terminal (DO), can be used as an open-collector digital output terminal (Y2).

0: Pulse output (FMP)

1: Switch signal output (FMR)

DO as a pulse output, the maximum frequency of the output pulse is 100kHz, DO-related functions, see Note F3.06.



F3.01	Y1function (open collector output terminal)	Range:0~45	Default:1
F3.02	Y2function (open collector output terminal)	Range:0~45	Default:0
F3.03	R relay output function selection	Range:0~45	Default:2
F3.04	E relay output function selection	Range:0~45	Default:0

Definition digital output terminal Y1, Y2 and relay R, E functions. Y2 / DO terminal as a high-speed pulse output, not F3.02 setting function, but set in the F3.06.

Table 7-4 Functions of output terminals

Value	Function	Description
0	No output	
1	inverter running	When the inverter is running and has output frequency(can be zero), the terminal becomes ON.
2	Fault output (stop)	When the inverter stops due to a fault, the terminal becomes ON.
3	Frequency-level detection FDT1 output	Refer to the descriptions of F4.19,F4.20.
4	Frequency reached	When the output frequency and set frequency error is less than F4.21 (percentage of the maximum frequency with respect to) the set value, the output ON.
5	Zero-speed running (no output at stop)	If the inverter runs with the output frequency of 0, the terminal becomes ON. If the inverter is in the stop state,the terminal becomes OFF.
6	Motor overload pre-warning	The inverter judges whether the motor load exceeds the overload pre-warning threshold before performing the protection action. If the pre-warning threshold is exceeded,the terminal becomes ON. For motor overload parameters,see the descriptions of F9.00~F9.02.
7	inverter overload pre-warning	The terminal becomes ON 10s before the inverter overload protection action is performed.
8	Set count value reached	The terminal becomes ON when the count value reaches the value set in Fb.08
9	Designated count value reached	The terminal becomes ON when the count value reaches the value set in group Fb
10	Length reached	The terminal becomes ON when the detected actual length exceeds the value set in Fb.05
11	PLC cycle complete	When simple PLC completes one cycle, the terminal outputs a pulse signal with width of 250 ms.
12	Accumulative running time reached	If the accumulative running time of the inverter exceeds the time set in F4.17, the terminal becomes ON

13	Frequency limited	If the set frequency exceeds the frequency upper limit or lower limit and the output frequency of the inverter reaches the upper limit or lower limit, the terminal becomes ON.
14	Torque limited	In speed control mode, if the output torque reaches the torque limit, the inverter enters the stall protection state and meanwhile the terminal becomes ON.
15	Ready for RUN	If the inverter main circuit and control circuit become stable, and the inverter detects no fault and is ready for RUN, the terminal becomes ON.
16	AI1>AI2	When the input of AI1 is larger than the input of AI2, the terminal becomes ON.
17	Frequency upper limit reached	If the running frequency reaches the upper limit, the terminal becomes ON.
18	Frequency lower limit reached (no output at stop)	If the running frequency reaches the lower limit, the terminal becomes ON. In the stop state, the terminal becomes OFF.
19	Under voltage state output	If the inverter is in undervoltage state, the terminal becomes ON.
20	Communication setting	Refer to the communication protocol.
23	Zero-speed running 2 (having output at stop)	If the output frequency of the inverter is 0, the terminal becomes ON. In the state of stop, the signal is still ON.
24	Accumulative power-on time reached	If the inverter accumulative power-on time (F8.13)exceeds the value set in F4.16, the terminal becomes ON.
25	Frequency level detection FDT2 output	Refer to the descriptions of F4.28 and F4.29
26	Frequency 1 reached	Refer to the descriptions of F4.30 and F4.31
27	Frequency 2 reached	Refer to the descriptions of F4.32 and F4.33
28	Current 1 reached	Refer to the descriptions of F4.38 and F4.39
29	Current 2 reached	Refer to the descriptions of F4.40 and F4.41
30	Timing reached	If the timing function (F4.42) is valid, the terminal becomes ON after the current running time of the inverter reaches the set time.
31	AI1 input limit exceeded	If AI1 input is larger than the value of F4.46 (AI1 input voltage upper limit) or lower than the value of F4.45 (AI1 input voltage lower limit), the terminal becomes ON.
32	Load becoming 0	If the load becomes 0, the terminal becomes ON.
33	Reverse running	If the inverter is in the reverse running state, the terminal becomes ON.
34	Zero current state	Refer to the descriptions of F4.34 ,F4.35
35	Module temperature reached	If the heatsink temperature of the inverter module (F8.07)reaches the set module temperature threshold (F4.47), the terminal becomes ON
36	Software current limit exceeded	Refer to the descriptions of F4.36,F4.37

37	Frequency lower limit reached (having output at stop)	If the running frequency reaches the lower limit, the terminal becomes ON. In the stop state, the signal is still ON
38	Alarm output	If a fault occurs on the inverter and the inverter continues to run, the terminal outputs the alarm signal.
40	Current running time reached	If the current running time of inverter exceeds the value of F4.53, the terminal becomes ON.
41	Analog levels:ADT1	Output OFF when the analog input voltage is higher than F4.57, the output is ON, less than F4.56
42	Analog levels:ADT2	When the analog input voltage is higher than F4.59, output ON, OFF output below the F4.58
43	Keep	
44	The X1 state	The X1 current state
45	The X2 state	The X2 current state

F3.06	DO output function selection	Range:0~16	Default:0
F3.07	AO1output function selection	Range:0~16	Default:0
F3.08	AO2output function selection	Range:0~16	Default:1

DO terminal output pulse frequency range of 0.01kHz ~ F3.09 (DO maximum output frequency), F3.09 can be set between 0.01kHz ~ 100.00kHz.

Analog output AO1 and AO2 output range of 0V ~ 10V, or 0mA ~ 20mA.

Pulse output or analog output range, with the corresponding scaling function relationships in the table below:

Value	Function	Range
0	Running frequency	0 to maximum output frequency
1	Set frequency	0 to maximum output frequency
2	Output current	0 to 2 times of rated motor current
3	Output torque	0 to 2 times of rated motor torque
4	Output power	0 to 2 times of rated power
5	Output voltage	0 to 1.2 times of rated inverter voltage
6	Pulse input	0.01kHz~100.00kHz
7	AI1	0V~10V
8	AI2	0V~10V (0~20mA)
9	AI3	0V~10V
10	Length	0 to maximum set length
11	Count value	0 to maximum count value
12	Communication setting	0.0%~100.0%
13	Motor rotational speed	0 to rotational speed corresponding to maximum output frequency
14	Output current	0.0A~1000.0A
15	Output voltage	0.0V~1000.0V

F3.09	Maximum output Frequency of DO	Range:0.01kHz~100.00kHz	Default:50.00Hz
-------	--------------------------------	-------------------------	-----------------

If the Y2/DO terminal is used for pulse output, this parameter is used to set the maximum

frequency of pulse output.

F3.10	AO1 offset coefficient	Range:-100.0~+100.0	Default:0.0
F3.11	AO1 gain	Range:-10.00~+10.00	Default:1.00

These parameters are used to correct the zero drift of analog output and the output amplitude deviation. They can also be used to define the desired AO curve.

If "b" represents zero offset, "k" represents gain, "Y" represents actual output, and "X" represents standard output, the actual output is:  $Y = kX + b$ .

The zero offset coefficient 100% of AO1 and AO2 corresponds to 10 V (or 20 mA). The standard output refers to the value corresponding to the analog output of 0 to 10 V (or 0 to 20 mA) with no zero offset or gain adjustment.

For example, if the analog output is used as the running frequency, and it is expected that the output is 8 V when the frequency is 0 and 3 V at the maximum frequency, the gain shall be set to -0.50, and the zero offset shall be set to 80%.

F3.12	AO2 offset coefficient	Range:-100.0~+100.0	Default:0.0
F3.13	AO2 gain	Range:-10.00~+10.00	Default:1.00

Reference to F3.10 and F3.11.

F3.14	Y1 output delay time	Range:0.0s~3600.0s	Default:0.0s
F3.15	Y2 output delay time	Range:0.0s~3600.0s	Default:0.0s
F3.16	R output delay time	Range:0.0s~3600.0s	Default:0.0s
F3.17	E output delay time	Range:0.0s~3600.0s	Default:0.0s

These parameters are used to set the delay time of output terminals Y1, Y2, relay R, relay E from status change to actual output.

F3.19	Output terminals valid mode selection	Range:0000~1111	Default:0000
-------	---------------------------------------	-----------------	--------------

It is used to set the logic of output terminals Y1, Y2, relay R, .relay R

0: Positive logic

The output terminal is valid when being connected with COM, and invalid when being disconnected from COM.

1: Positive logic

The output terminal is invalid when being connected with COM, and valid when being disconnected from COM.

Bit3	Bit2	Bit1	Bit0
E	R	Y2	Y1

### Group F4: Auxiliary Functions

F4.00	JOG running frequency	Range:0.00Hz~the maximum frequency	Default:2.00Hz
F4.01	JOG acceleration time	Range:0.0s~6500.0s	Default:20.0s
F4.02	JOG deceleration time	Range:0.0s~6500.0s	Default:20.0s

These parameters are used to define the set frequency and acceleration/deceleration time of the inverter when jogging. The startup mode is "Direct start" (F7.00 = 0) and the stop mode is "Decelerate to stop" (F7.10 = 0) during jogging.

F4.03	Acceleration time 2	Range:0.0s~6500.0s	Default:Model dependent
F4.04	Deceleration time 2	Range:0.0s~6500.0s	Default:Model dependent
F4.05	Acceleration time 3	Range:0.0s~6500.0s	Default:Model dependent
F4.06	Deceleration time 3	Range:0.0s~6500.0s	Default:Model dependent

			dependent
F4.07	Acceleration time 4	Range:0.0s~6500.0s	Default:Model dependent
F4.08	Deceleration time 4	Range:0.0s~6500.0s	Default:Model dependent

The JT580 provides a total of four groups of acceleration/deceleration time, that is, the preceding three groups and the group defined by F0.17 and F0.18. Definitions of four groups are completely the same. You can switch over between the four groups of acceleration/deceleration time through different state combinations of X terminals. For more details, see the descriptions of F2.01 to F2.05.

F4.09	Jump frequency 1	Range:0.00Hz~the maximum frequency	Default:0.00Hz
F4.10	Jump frequency 2	Range:0.00Hz~the maximum frequency	Default:0.00Hz
F4.11	Frequency jump amplitude	Range:0.00Hz~the maximum frequency	Default:0.01Hz

If the set frequency is within the frequency jump range, the actual running frequency is the jump frequency close to the set frequency. Setting the jump frequency helps to avoid the mechanical resonance point of the load.

The JT580 supports two jump frequencies. If both are set to 0, the frequency jump function is disabled. The principle of the jump frequencies and jump amplitude is shown in the following Figure .

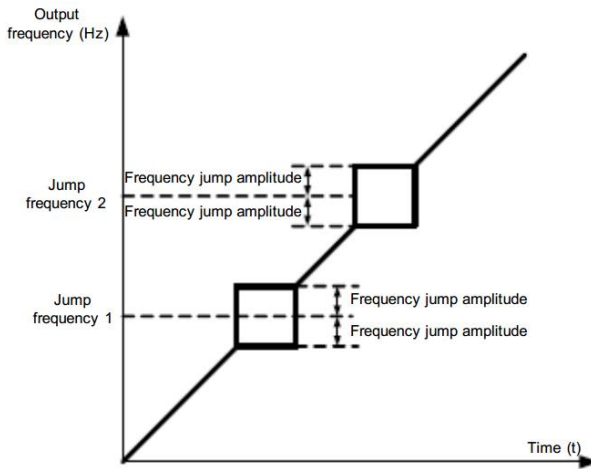

Figure7.8 Principle of the jump frequencies and jump amplitude

F4.12	Forward/Reverse rotation dead-zone time	Range:0.0s~3000.0s	Default:0.0s
-------	---	--------------------	--------------

It is used to set the time when the output is 0 Hz at transition of the inverter forward rotation and reverse rotation, as shown in the following Figure .

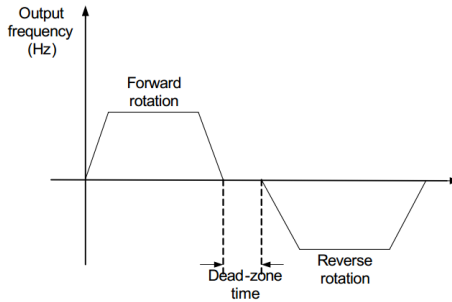

Figure7.9 Forward/Reverse rotation dead-zone time

F4.13	Reverse control	Range:0~1	Default:0
-------	-----------------	-----------	-----------

- 0: Enabled
- 1: Disabled

It is used to set whether the inverter allows reverse rotation. In the applications where reverse rotation is prohibited, set this parameter to 1.

F4.14	Running mode when set frequency lower than frequency lower limit	Range:0~2	Default:0
-------	--	-----------	-----------

It is used to set the inverter running mode when the set frequency is lower than the frequency lower limit. The JT580 provides three running modes to satisfy requirements of various applications

- 0: Run at frequency lower limit
- 1: Stop
- 2: Run at zero speed

F4.15	Droop control	Range:0.00Hz~10.00Hz	Default:0.00Hz
-------	---------------	----------------------	----------------

his function is typically used for load sharing with multiple motors drag a load. Droop control refers to as the load increases, the inverter output frequency decreases, so more than one motor drive the same load, the load of the motor output frequency drops more, which can reduce the load on the motor to achieve multiple motors load evenly.

This parameter refers to the inverter rated output load, the output frequency decreases value.

F4.16	Accumulative power-on time threshold	Range:0s~65000h	Default:0h
-------	--------------------------------------	-----------------	------------

If the accumulative power-on time (F8.13) reaches the value set in this parameter, the corresponding DO terminal becomes ON.

F4.17	Accumulative running time threshold	Range:0s~65000h	Default:0h
-------	-------------------------------------	-----------------	------------

It is used to set the accumulative running time threshold of the inverter. If the accumulative running time (F8.13) reaches the value set in this parameter, the corresponding digital output terminal becomes ON.

F4.18	Startup protection	Range:0~1	Default:0
-------	--------------------	-----------	-----------

This parameter is used to set whether to enable the safety protection. If it is set to 1, the inverter does not respond to the run command valid upon inverter power-on (for example, an input terminal is ON before power-on). The inverter responds only after the run command is

canceled and becomes valid again. In addition, the inverter does not respond to the run command valid upon fault reset of the inverter. The run protection can be disabled only after the run command is canceled.

In this way, the motor can be protected from responding to run commands upon power-on or fault reset in unexpected conditions.

F4.19	Frequency detection value (FDT1)	Range:0.00Hz~the maximum frequency	Default:50.00Hz
F4.20	Frequency detection hysteresis (FDT hysteresis 1)	Range:0.0%~100.0%	Default:5.0%

If the running frequency is higher than the value of F4.19, the corresponding Y terminal becomes ON. If the running frequency is lower than value of F4.19, the DO terminal goes OFF.

These two parameters are respectively used to set the detection value of output frequency and hysteresis value upon cancellation of the output. The value of F4.20 is a percentage of the hysteresis frequency to the frequency detection value (F4.19). The FDT function is shown in the following Figure .

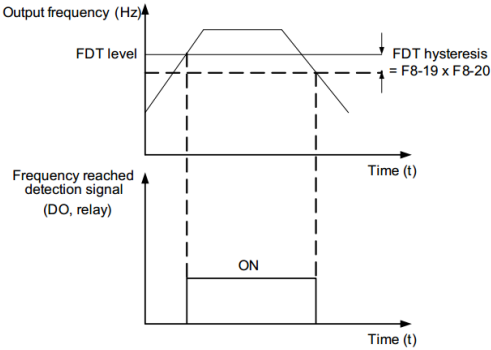

Figure7.10 FDT level

F4.21	Detection range of frequency reached	Range:0.0%~100.0%	Default:0.0%
-------	--------------------------------------	-------------------	--------------

If the inverter running frequency is within the certain range of the set frequency, the corresponding DO terminal becomes ON.

This parameter is used to set the range within which the output frequency is detected to reach the set frequency. The value of this parameter is a percentage relative to the maximum frequency. The detection range of frequency reached is shown in the following figure .

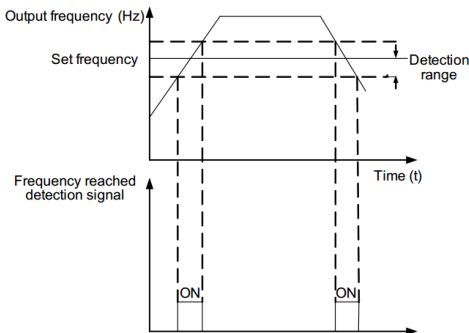

Figure 7.11 Detection range of frequency reached

F4.22	Jump frequency during acceleration/deceleration	Range:0~1	Default:0
-------	---	-----------	-----------

0: Disabled  
1: Enabled

It is used to set whether the jump frequencies are valid during acceleration/deceleration. When the jump frequencies are valid during acceleration/deceleration, and the running frequency is within the frequency jump range, the actual running frequency will jump over the set frequency jump amplitude.

F4.25	Frequency switchover point between acceleration time 1 and acceleration time 2	Range:0.00Hz~maximum frequency	Default:0.00Hz
F4.26	Frequency switchover point between deceleration time 1 and deceleration time 2	Range:0.00Hz~maximum frequency	Default:0.00Hz

This function is valid when motor 1 is selected and acceleration/deceleration time switchover is not performed by means of X terminal. It is used to select different groups of acceleration/deceleration time based on the running frequency range rather than X terminal during the running process of the inverter.

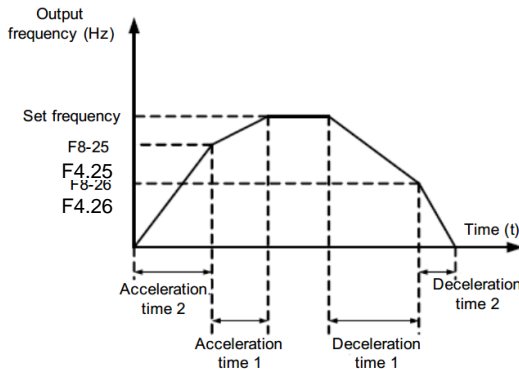

Figure 7.12 Acceleration/deceleration time switchover

During acceleration, if the running frequency is smaller than the value of F4.25, acceleration time 2 is selected. If the running frequency is larger than the value of F4.25, acceleration time 1 is selected.

During deceleration, if the running frequency is larger than the value of F4.26, deceleration time 1 is selected. If the running frequency is smaller than the value of F4.26, deceleration time 2 is selected.

F4.27	Terminal JOG preferred	Range:0~1	Default:0
-------	------------------------	-----------	-----------

0: Disabled  
1: Enabled

It is used to set whether terminal JOG is preferred.

If terminal JOG is preferred, the inverter switches to terminal JOG running state when there is a terminal JOG command during the running process of the inverter.

F4.28	Frequency detection value (FDT2)	Range:0.00Hz~maximum frequency	Default:50.00Hz
-------	----------------------------------	--------------------------------	-----------------



F4.29	Frequency detection hysteresis (FDT hysteresis 2)	Range:0.0%~100.0%	Default:5.0%
-------	---	-------------------	--------------

Refer to description of F4.19, F4.20.

F4.30	Any frequency reaching detection value 1	Range:0.00Hz~maximum frequency	Default:50.00Hz
F4.31	Any frequency reaching detection amplitude 1	Range:0.0%~100.0%	Default:0.0%
F4.32	Any frequency reaching detection value 2	Range:0.00Hz~maximum frequency	Default:50.00Hz
F4.33	Any frequency reaching detection amplitude 2	Range:0.0%~100.0%	Default:0.0%

If the output frequency of the inverter is within the positive and negative amplitudes of the any frequency reaching detection value, the corresponding digital output becomes ON.

The JT580 provides two groups of any frequency reaching detection parameters, including frequency detection value and detection amplitude, as shown in the following figure .

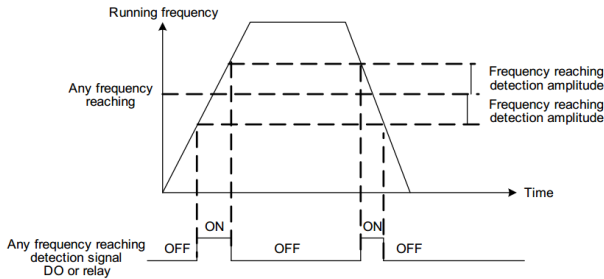

Figure 7.13 Any frequency reaching detection

F4.34	Zero current detection level	Range:0.0%~300.0%	Default:5.0%
F4.35	Zero current detection delay time	Range:0.01s~600.00s	Default:0.10s

If the output current of the inverter is equal to or less than the zero current detection level and the duration exceeds the zero current detection delay time, the corresponding output terminal becomes ON. The zero current detection is shown in the following figure .

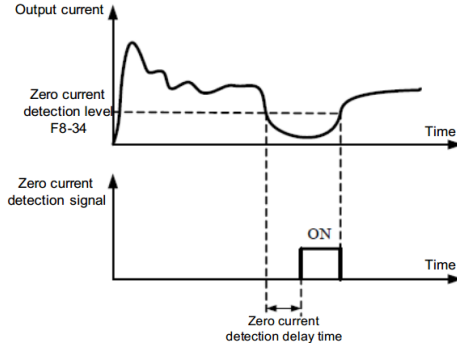

Figure 7.14 Zero current detection

F4.36	Output overcurrent threshold	Range: 0.0%~300.0%	Default:200.0%
F4.37	Output overcurrent detection delay time	Range:0.00s~600.00s	Default:0.00s

If the output current of the inverter is equal to or higher than the overcurrent threshold and the duration exceeds the detection delay time, the corresponding output terminal becomes ON. The output overcurrent detection function is shown in the following Figure .

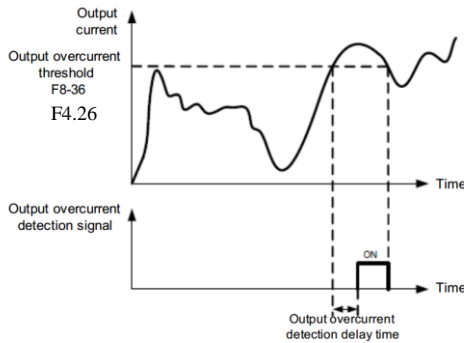

Figure 7.15 Output overcurrent detection

F4.38	Any current reaching 1	Range:0.0%~300.0%	Default:100.0%
F4.39	Any current reaching 1 amplitude	Range:0.0%~300.0%	Default:0.0%
F4.40	Any current reaching 2	Range:0.0%~300.0%	Default:100.0%
F4.41	Any current reaching 2 amplitude	Range:0.0%~300.0%	Default:0.0%

If the output current of the inverter is within the positive and negative amplitudes of any current reaching detection value, the corresponding output terminal becomes ON.

The JT580 provides two groups of any current reaching detection parameters, including current detection value and detection amplitudes, as shown in the following Figure .

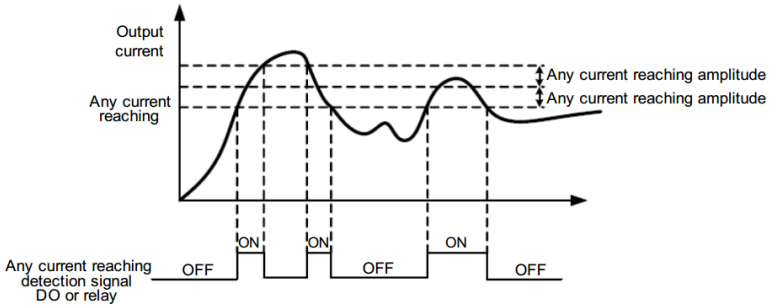

Figure 7.16 Any current reaching detection

F4.42	Timing function	Range:0~1	Default:0
-------	-----------------	-----------	-----------

0: Disabled

1: Enabled

F4.43	Timing duration source	Range:0~3	Default:0
-------	------------------------	-----------	-----------

0:F4.44

1:AI1

2:AI2

3:AI3(100% of analog input corresponds to the value of F4.44)

F4.44	Timing duration	Range:0.0Min~6500.0Min	Default:0.0Min
-------	-----------------	------------------------	----------------

These parameters are used to implement the inverter timing function.

If F4.42 is set to 1, the inverter starts to time at startup. When the set timing duration is reached, the inverter stops automatically and meanwhile the corresponding DO becomes ON.

The inverter starts timing from 0 each time it starts up and the remaining timing duration can be queried by H0.28.

The timing duration is set in F4.43 and F4.44, in unit of minute.

F4.45	AI1 input voltage lower limit	Range:0.00V~F4.46	Default:3.10V
-------	-------------------------------	-------------------	---------------

F4.46	AI1 input voltage upper limit	Range:F4.45~10.00V	Default:6.80V
-------	-------------------------------	--------------------	---------------

These two parameters are used to set the limits of the input voltage to provide protection on

the inverter. When the AI1 input is larger than the value of F4.46 or smaller than the value of F4.45, the corresponding output terminal becomes ON, indicating that AI1 input exceeds the limit.

F4.47	Module temperature threshold	Range:0~100	Default:75℃
-------	------------------------------	-------------	-------------

When the heatsink temperature of the inverter reaches the value of this parameter, the corresponding output terminal becomes ON, indicating that the module temperature reaches the threshold.

F4.48	Cooling fan control	Range:0~1	Default:0
-------	---------------------	-----------	-----------

It is used to set the working mode of the cooling fan. If this parameter is set to 0, the fan works when the inverter is in running state. When the inverter stops, the cooling fan works if the heatsink temperature is higher than 40℃, and stops working if the heatsink temperature is lower than 40℃.

If this parameter is set to 1, the cooling fan keeps working after power on.

F4.49	Wakeup frequency	Range:F4.51~F0.10	Default:0.00Hz
-------	------------------	-------------------	----------------

F4.50	Wakeup delay time	Range:0.0s~6500.0s	Default:0.0s
F4.51	Dormant frequency	Range:0.00Hz~F4.49	Default:0.00Hz
F4.52	Dormant delay time	Range:0.0~6500.0s	Default:0.0s

These parameters are used to implement the dormant and wakeup functions in the water supply application.

When the inverter is in running state, the inverter enters the dormant state and stops automatically after the dormant delay time (F4.52) if the set frequency is lower than or equal to the dormant frequency (F4.51).

When the inverter is in dormant state and the current running command is effective, the inverter starts up after the wakeup delay time (F4.50) if the set frequency is higher than or equal to the wakeup frequency (F4.49).

Generally, set the wakeup frequency equal to or higher than the dormant frequency. If the wakeup frequency and dormant frequency are set to 0, the dormant and wakeup functions are disabled.

When the dormant function is enabled, if the frequency source is PID, whether PID operation is performed in the dormant state is determined by FA.28. In this case, select PID operation enabled in the stop state (FA.28 = 1).

F4.53	Current running time reached	Range:0.0Min~6500.0Min	Default:0.0Min
-------	------------------------------	------------------------	----------------

If the current running time reaches the value set in this parameter, the corresponding output terminal becomes ON, indicating that the current running time is reached.

F4.54	ADT1 channel selection	Unit's digit: 0:AI1 1:AI2 Ten's digit: 0:No output when stop 1:Output when stop	Default:00
F4.55	ADT2 channel selection	Unit's digit: 0:AI1 1:AI2 Ten's digit: 0:No output when stop 1:Output when stop	Default:01
F4.56	ADT1 output upper limit	F4.57~10.00	Default:10.00V
F4.57	ADT1 output lower limit	0.00~F4.56	Default:0.00V
F4.58	ADT2 output upper limit	F4.59~10.00	Default:10.00V
F4.59	ADT2 output lower limit	0.00~F4.58	Default:0.00V

When the AI voltage is higher than the ADT upper limit value, the inverter function output terminal (41/42: Frequency detection ADT1 / ADT2 output) will be ON, and the frequency is below the lower limit value of ADT, the ON signal is canceled.

## Group F5: Vector Control Parameters

F5.00	Speed loop proportional gain 1	1~100	Default:30
-------	--------------------------------	-------	------------

F5.01	Speed loop integral time 1	0.01s~10.00s	Default:0.50s
F5.02	Switchover frequency 1	0.00~F5.05	Default:5.00Hz
F5.03	Speed loop proportional gain 2	1~100	Default:20
F5.04	Speed loop integral time 2	0.01s~10.00s	Default:1.00s
F5.05	Switchover frequency 2	F5.02~maximum frequency	Default:10.00Hz

The parameters of this group is only valid for vector control, not for V / F control.Speed loop PI parameters vary with running frequencies of the inverter.

If the running frequency is less than or equal to "Switchover frequency 1" (F5.02), the speed loop PI parameters are F5.00 and F5.01.

If the running frequency is equal to or greater than "Switchover frequency 2" (F5.05), the speed loop PI parameters are F5.03 and F5.04.

If the running frequency is between F2.02 and F2.05, the speed loop PI parameters are obtained from the linear switchover between the two groups of PI parameters, as shown in Figure 6.17.

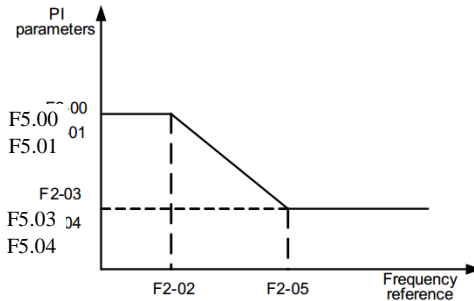

Figure 7.17 Relationship between running frequencies and PI parameters

The speed dynamic response characteristics in vector control can be adjusted by setting the proportional gain and integral time of the speed regulator.To achieve a faster system response, increase the proportional gain and reduce the integral time. Be aware that this may lead to system oscillation.

The recommended adjustment method is as follows:If the factory setting cannot meet the requirements, make proper adjustment. Increase the proportional gain first to ensure that the system does not oscillate, and then reduce the integral time to ensure that the system has quick response and small overshoot.

Note:Improper PI parameter setting may cause too large speed overshoot, and overvoltage fault may even occur when the overshoot drops.

F5.06	Vector control slip gain	Range:50%~200%	Default:100%
-------	--------------------------	----------------	--------------

For SFVC, it is used to adjust speed stability accuracy of the motor. When the motor with load runs at a very low speed, increase the value of this parameter; when the motor with load runs at a very large speed, decrease the value of this parameter.

For CLVC, it is used to adjust the output current of the inverter with same load.

F5.07	Time constant of speed loop filter	Range:0.000s~0.100s	Default:0.000s
-------	------------------------------------	---------------------	----------------

In the vector control mode, the output of the speed loop regulator is torque current reference. This parameter is used to filter the torque references. It need not be adjusted generally and can be increased in the case of large speed fluctuation. In the case of motor

oscillation, decrease the value of this parameter properly.

If the value of this parameter is small, the output torque of the inverter may fluctuate greatly, but the response is quick.

F5.08	Vector control overexcitation gain	Range:0~200	Default:64
-------	------------------------------------	-------------	------------

During deceleration of the inverter, over-excitation control can restrain rise of the bus voltage to avoid the overvoltage fault. The larger the over-excitation gain is, the better the restraining effect is.

Increase the over-excitation gain if the inverter is liable to overvoltage error during deceleration. Too large over-excitation gain, however, may lead to an increase in output current. Therefore, set this parameter to a proper value in actual applications.

Set the over-excitation gain to 0 in applications of small inertia (the bus voltage will not rise during deceleration) or where there is a braking resistor.

F5.09	Torque upper limit source in speed control mode	Range:0~7	Default:0
F5.10	Digital setting of torque upper limit in speed control mode	Range:0.0%~200.0%	Default:150.0%

0: A2-48

1: AI1

2: AI2

3: AI3

4: Pulse setting (X5)

5: Via communication

6: MIN(AI1,AI2)

7: MAX(AI1,AI2)

When the inverter is in communication with the master, if F5.09 is set to 5 “communication setting”, F5.10 “Digital setting of torque upper limit in speed control mode” can be set via communication from the master.

In other conditions, the host computer writes data -100.00% to 100.00% by the communication address 0x1000, where 100.0% corresponds to the value of F5.10. The communication protocol can be Modbus.

F5.11	Torque upper limit source in speed control mode(In Regenerative State)	Range:0~7	Default:0
F5.12	Digital setting of torque upper limit in speed control mode (In Regenerative State)	Range:0.0%~200.0%	Default:150.0%

0: Set by F5.12

1: AI1

2: AI2

3: AI3

4: Pulse setting (X5)

5: Via communication

6: MIN(AI1,AI2)

7: MAX(AI1,AI2)

When the inverter is in communication with the master, if F5.11 is set to 5 “communication setting”, F5.12 “Digital setting of torque upper limit in speed control mode” can be set via communication from the master.

In other conditions, the host computer writes data -100.00% to 100.00% by the communication address 0x1000, where 100.0% corresponds to the value of F5.12.

F5.13	Excitation adjustment proportional gain	Range:0~60000	Default:2000
F5.14	Excitation adjustment integral gain	Range:0~60000	Default:1300
F5.15	Torque adjustment proportional gain	Range:0~60000	Default:2000
F5.16	Torque adjustment integral gain	Range:0~60000	Default:1300

These are current loop PI parameters for vector control. These parameters are automatically obtained through "Asynchronous motor complete auto-tuning" or "Synchronous motor noload auto-tuning", and need not be modified.

The dimension of the current loop integral regulator is integral gain rather than integral time. Note that too large current loop PI gain may lead to oscillation of the entire control loop. Therefore, when current oscillation or torque fluctuation is great, manually decrease the proportional gain or integral gain here.

### Group F6: V/F Control Parameters

Group F6 is valid only for V/F control.

F6.00	V/F curve setting	Range:0~8	Default:0
-------	-------------------	-----------	-----------

0: Linear V/F

It is applicable to common constant torque load.

1: Multi-point V/F

It is applicable to special load such as dehydrator and centrifuge. Any such V/F curve can be obtained by setting parameters of F6.03 to F6.08.

2: Square V/F

3: 1.2-power V/F

4: 1.4-power V/F

6: 1.6-power V/F

8: 1.8-power V/F

2 to 8 is suitable for fans, pumps, centrifugal loads

F6.01	Torque boost	Range:0.0~30.0	Default:Model dependent
F6.02	Cut-off frequency of torqueboost	Range:0.00Hz~maximum frequency	Default:50.00Hz

To compensate the low frequency torque characteristics of V/F control, you can boost the output voltage of the inverter at low frequency by modifying F6.01.

If the torque boost is set to too large, the motor may overheat, and the inverter may suffer overcurrent. If the load is large and the motor startup torque is insufficient, increase the value of F6.01. If the load is small, decrease the value of F6.01. If it is set to 0.0, the inverter performs automatic torque boost. In this case, the inverter automatically calculates the torque boost value based on motor parameters including the stator resistance.

F6.02 specifies the frequency under which torque boost is valid. Torque boost becomes invalid when this frequency is exceeded, as shown in the following Figure .

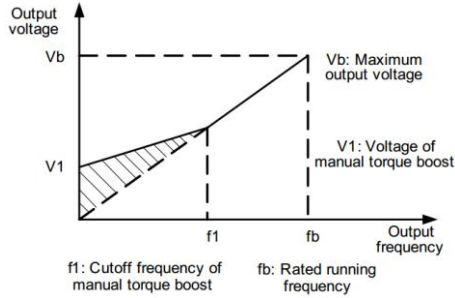

Figure 7.18 Manual torque boost

F6.03	Multi-point V/F frequency 1	Range:0.00Hz~F6.05	Default:0.00Hz
F6.04	Multi-point V/F voltage 1	Range:0.0%~100.0%	Default:0.0%
F6.05	Multi-point V/F frequency 2	Range:F6.03~F6.07	Default:0.00Hz
F6.06	Multi-point V/F voltage 2	Range:0.0%~100.0%	Default:0.0%
F6.07	Multi-point V/F frequency 3	Range:F6.05~rated motor frequency (F1.04)	Default:0.00Hz
F6.08	Multi-point V/F voltage 3	Range:0.0%~100.0%	Default:0.0%

These six parameters are used to define the multi-point V/F curve.

The multi-point V/F curve is set based on the motor's load characteristic. The relationship between voltages and frequencies is:  $V1 < V2 < V3$ ,  $F1 < F2 < F3$

At low frequency, higher voltage may cause overheat or even burnt out of the motor and overcurrent stall or overcurrent protection of the inverter.

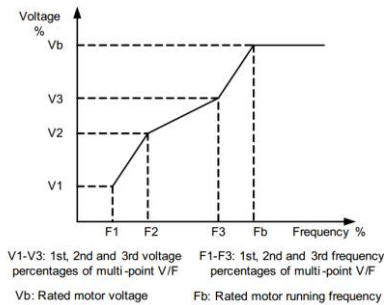

Figure 7.19 Setting of multi-point V/F curve

F6.09	V/F slip compensation gain	Range:0.0%~200.0%	Default:0.0%
-------	----------------------------	-------------------	--------------

This parameter is valid only for the asynchronous motor.

It can compensate the rotational speed slip of the asynchronous motor when the load of the motor increases, stabilizing the motor speed in case of load change. If this parameter is set to 100%, it indicates that the compensation when the motor bears rated load is the rated motor slip. The rated motor slip is automatically obtained by the inverter through calculation based on the rated motor frequency and rated motor rotational speed in group F1.

Generally, if the motor rotational speed is different from the target speed, slightly adjust this parameter.

F6.10	V/F over-excitation gain	Range:0~200	Default:64
-------	--------------------------	-------------	------------



During deceleration of the inverter, over-excitation can restrain rise of the bus voltage, preventing the overvoltage fault. The larger the over-excitation is, the better the restraining result is.

Increase the over-excitation gain if the inverter is liable to overvoltage error during deceleration. However, too large over-excitation gain may lead to an increase in the output current. Set F6.09 to a proper value in actual applications.

Set the over-excitation gain to 0 in the applications where the inertia is small and the bus voltage will not rise during motor deceleration or where there is a braking resistor.

F6.11	V/F oscillation suppression gain	Range:0~100	Default:Mode dependent
-------	----------------------------------	-------------	------------------------

Set this parameter to a value as small as possible in the prerequisite of efficient oscillation suppression to avoid influence on V/F control.

Set this parameter to 0 if the motor has no oscillation. Increase the value properly only when the motor has obvious oscillation. The larger the value is, the better the oscillation suppression result will be.

When the oscillation suppression function is enabled, the rated motor current and no-load current must be correct. Otherwise, the V/F oscillation suppression effect will not be satisfactory.

F6.13	Limited flow protection function selection	Range: 0~1	Default: 0
-------	--	------------	------------

This feature is used to limit flow protection

0: invalid

1: valid

F6.14	Current limiting protection value	Range: 0~600 (A)	Default: 70
F6.15	Limited current protection action time	Range: 0.0~60.0 (s)	Default: 02.0

When F6.13 (set to: 1) effectively, the inverter running current after reaching current-limiting protection value (F6.14), and the duration of the current reach current-limiting protection action time (F6.15) value, the frequency converter to jump ERR28 failure.

### Group F7: Start/Stop Control

F7.00	Start mode	Range:0~2	Default:0
-------	------------	-----------	-----------

0: Direct start

– If the DC braking time is set to 0, the inverter starts to run at the startup frequency.

– If the DC braking time is not 0, the inverter performs DC braking first and then starts to run at the startup frequency. It is applicable to small-inertia load application where the motor is likely to rotate at startup.

1: Rotational speed tracking restart

The inverter judges the rotational speed and direction of the motor first and then starts at the tracked frequency. Such smooth start has no impact on the rotating motor. It is applicable to the restart upon instantaneous power failure of large-inertia load. To ensure the performance of rotational speed tracking restart, set the motor parameters

in group F1 correctly.

2: DC braking restart

DC brake firstly, then restart.

F7.01	Rotational speed tracking mode	Range:0~2	Default:0
-------	--------------------------------	-----------	-----------

To complete the rotational speed tracking process within the shortest time, select the proper mode in which the inverter tracks the motor rotational speed.

0: From frequency at stop

It is the commonly selected mode.

1: From zero frequency

It is applicable to restart after a long time of power failure.

2: From the maximum frequency

It is applicable to the power-generating load.

F7.02	Rotational speed tracking speed	Range:1~100	Default:20
-------	---------------------------------	-------------	------------

In the rotational speed tracking restart mode, select the rotational speed tracking speed. The larger the value is, the faster the tracking is. However, too large value may cause unreliable tracking.

F7.03	Startup frequency	Range:0.00Hz~10.00 Hz	Default:0.00Hz
F7.04	Startup frequency holding time	Range:0.0s~100.0s	Default:0.0s

To ensure the motor torque at inverter startup, set a proper startup frequency. In addition, to build excitation when the motor starts up, the startup frequency must be held for a certain period.

The startup frequency (F7.03) is not restricted by the frequency lower limit. If the set target frequency is lower than the startup frequency, the inverter will not start and stays in the standby state.

During switchover between forward rotation and reverse rotation, the startup frequency holding time is disabled. The holding time is not included in the acceleration time but in the running time of simple PLC.

F7.05	Startup DC braking current	Range:0%~100%	Default:0%
F7.06	Startup DC braking time	Range:0.0s~100.0s	Default:0.0s

Startup DC braking is generally used during restart of the inverter after the rotating motor stops.

Startup DC braking is valid only for direct start (F7.00 = 0). In this case, the inverter performs DC braking at the set startup DC braking current. After the startup DC braking time, the inverter starts to run. If the startup DC braking time is 0, the inverter starts directly without DC braking. The larger the startup DC braking current is, the larger the braking force is.

The startup DC braking current or pre-excited current is a percentage relative to the base value.

- If the rated motor current is less than or equal to 80% of the rated inverter current, the base value is the rated motor current.
- If the rated motor current is greater than 80% of the rated inverter current, the base value is 80% of the rated inverter current.

F7.07	Acceleration/Deceleration mode	Range:0~2	Default:0
-------	--------------------------------	-----------	-----------

It is used to set the frequency change mode during the inverter start and stop process.

0: Linear acceleration/deceleration

The output frequency increases or decreases in linear mode. The JT580 provides four group of acceleration/deceleration time, which can be selected by using F4.03 to F4.08.

1: S-curve acceleration/deceleration A

The output frequency increases or decreases along the S curve. This mode is generally

used in the applications where start and stop processes are relatively smooth, such as elevator and conveyor belt. F7.08 and F7.09 respectively define the time proportions of the start segment and the end segment.

2: S-curve acceleration/deceleration B

In this curve, the rated motor frequency  $f_b$  is always the inflexion point. This mode is usually used in applications where acceleration/deceleration is required at the speed higher than the rated frequency.

When the set frequency is higher than the rated frequency, the acceleration/deceleration time is:

$$t = \left( \frac{4}{9} \times \left( \frac{f}{f_b} \right)^2 + \frac{5}{9} \right) \times T$$

In the formula,  $f$  is the set frequency,  $f_b$  is the rated motor frequency and  $T$  is the acceleration time from 0 Hz to  $f_b$ .

F7.08	Time proportion of S-curve start segment	Range:0.0%~(100.0%-F7.09)	Default:30.0%
F7.09	Time proportion of S-curve end segment	Range:0.0%~(100.0%-F7.08)	Default:30.0%

These two parameters respectively define the time proportions of the start segment and the end segment of S-curve acceleration/deceleration. They must satisfy the requirement:  $F7.08 + F7.09 \leq 100.0\%$ .

In Figure 6.20,  $t_1$  is the time defined in F7.08, within which the slope of the output frequency change increases gradually.  $t_2$  is the time defined in F7.09, within which the slope of the output frequency change gradually decreases to 0. Within the time between  $t_1$  and  $t_2$ , the slope of the output frequency change remains unchanged, that is, linear acceleration/Deceleration.

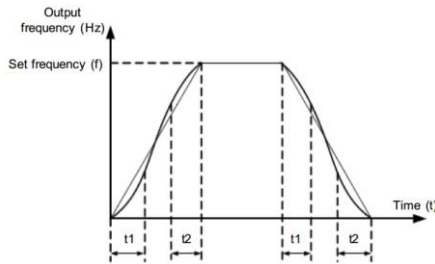

Figure7.20 S-curve acceleration/deceleration A

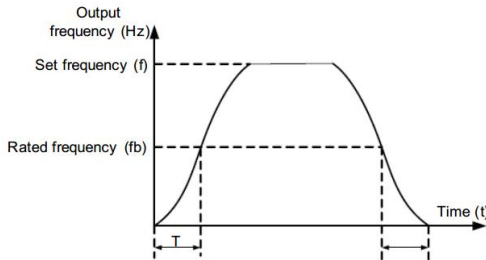

Figure 7.21 S-curve acceleration/deceleration B

F7.10	Stop mode	Range:0~1	Default:0
-------	-----------	-----------	-----------

0: Decelerate to stop

After the stop command is enabled, the inverter decreases the output frequency according to the deceleration time and stops when the frequency decreases to zero.

1: Coast to stop

After the stop command is enabled, the inverter immediately stops the output. The motor will coast to stop based on the mechanical inertia.

F7.11	Initial frequency of stop DC braking	Range:0.00Hz~maximum frequency	Default:0.00Hz
F7.12	Waiting time of stop DC braking	Range:0.0s~100.0s	Default:0.0s
F7.13	Stop DC braking current	Range:0%~100%	Default:0%
F7.14	Stop DC braking time	Range:0.0%~100.0%	Default:0.0s

F7.11 (Initial frequency of stop DC braking)

During the process of decelerating to stop, the inverter starts DC braking when the running frequency is lower than the value set in F7.11.

F7.12 (Waiting time of stop DC braking)

When the running frequency decreases to the initial frequency of stop DC braking, the inverter stops output for a certain period and then starts DC braking. This prevents faults such as overcurrent caused due to DC braking at high speed.

F7.13 (Stop DC braking current) This parameter specifies the output current at DC braking and is a percentage relative to the base value.

– If the rated motor current is less than or equal to 80% of the rated inverter current, the base value is the rated motor current.

– If the rated motor current is greater than 80% of the rated inverter current, the base value is 80% of the rated inverter current.

F7.14 (Stop DC braking time)

This parameter specifies the holding time of DC braking. If it is set to 0, DC braking is canceled.

The stop DC braking process is shown in the following Figure .

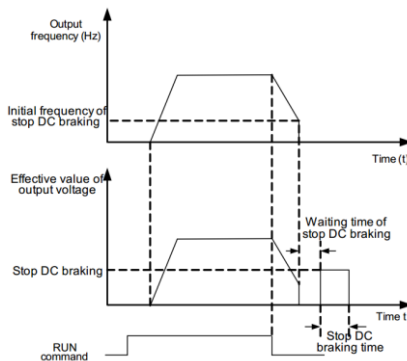

Figure 7.22 Stop DC braking process

F7.15	Brake use ratio	Range:0%~100%	Default:100%
-------	-----------------	---------------	--------------

It is valid only for the inverter with internal braking unit and used to adjust the duty ratio of the braking unit. The larger the value of this parameter is, the better the braking result will be. However, too larger value causes great fluctuation of the inverter bus voltage during the braking process.

**Group F8: Operation Panel and Display**

F8.01	MK Key function selection	Range:0~4	Default:0
-------	---------------------------	-----------	-----------

MK key refers to multifunctional key. You can set the function of the MK key by using this parameter. You can perform switchover by using this key both in stop or running state.

0: MK key disabled

This key is disabled.

1: Switchover between operation panel control and remote command control (terminal or communication)

You can perform switchover from the current command source to the operation panel control (local operation). If the current command source is operation panel control, this key is invalid.

2: Switchover between forward rotation and reverse rotation

You can change the direction of the frequency reference by using the MK key. It is valid only when the current command source is operation panel control.

3: Forward JOG

You can perform forward JOG (FJOG) by using the MK key.

4: Reverse JOG

You can perform reverse JOG (FJOG) by using the MK key.

F8.02	STOP/RESET key function	Range:0~1	Default:1
-------	-------------------------	-----------	-----------

0: STOP/RESET key enabled only in operation panel control

1: STOP/RESET key enabled in any operation mode

F8.03	LED display running parameters 1	Range:0x0000~0xFFFF	Default:0x001F
-------	----------------------------------	---------------------	----------------

The display running parameters is used to set parameters can be viewed when the drive is in operation . Check the status parameters for up to 32, according to the F8.03, F8.04 parameter values of the binary bits to select the state parameters to be displayed, the order from the lowest level F8.03.

Bit07	Bit06	Bit05	Bit04	Bit03	Bit02	Bit01	Bit00
X input status	Bus voltage	Output torque	Output power	Output voltage	Output current	Set frequency	Running frequency
Bit15	Bit14	Bit13	Bit12	Bit11	Bit10	Bit09	Bit08
PID feedback	PID setting	Pulse setting frequency	AI3 voltage	AI2 voltage	AI1 voltage	DO output status	Reserved

F8.04	LED display running parameters 2	Range:0x0000~0xFFFF	Default:0x0000
-------	----------------------------------	---------------------	----------------

Bit07	Bit06	Bit05	Bit04	Bit03	Bit02	Bit01	Bit00
Linear speed	Length value	Count value	feedback speed	Auxiliary frequency display	Main frequency display	Load speed display	PID output
Bit15	Bit14	Bit13	Bit12	Bit11	Bit10	Bit09	Bit08
Reserved	Communication setting value	PLC stage	Remaining running time	Output current percentage	Overload count	Current running time	Current power-on time

F8.05	LED display stop parameters	Range:0x0000~0xFFFF	Default:0x0033
-------	-----------------------------	---------------------	----------------

Bit07	Bit06	Bit05	Bit04	Bit03	Bit02	Bit01	Bit00
Count value	AI3 voltage	AI2 voltage	AI1 voltage	Digital output status	X input status	Bus voltage	Set frequency
Bit15	Bit14	Bit13	Bit12	Bit11	Bit10	Bit09	Bit08
			Pulse setting frequency	PID setting	Load speed	PLC stage	Length value

F8.06	Load speed display coefficient	Range:0.0001~6.5000	Default:1.0000
-------	--------------------------------	---------------------	----------------

This parameter is used to adjust the relationship between the output frequency of the inverter and the load speed. For details, see the description of F8.12.

F8.07	Heatsink temperature of Inverter module	Range:0.0°C~100.0°C	Default:-
-------	---	---------------------	-----------

It is used to display the insulated gate bipolar transistor (IGBT) temperature of the Inverter module, and the IGBT overheat protection value of the Inverter module depends on the model.

F8.09	Accumulative running time	Range:0~65535	Default:-
-------	---------------------------	---------------	-----------

It is used to display the accumulative running time of the inverter. After the accumulative running time reaches the value set in F4.17, the terminal with the digital output function 12 becomes ON.

F8.11	Software version	Range:0.00~655.35	Default:-
-------	------------------	-------------------	-----------

F8.12	Number of decimal places for load speed display	Range:0~3	Default:1
-------	---	-----------	-----------

F8.12 is used to set the number of decimal places for load speed display. The following gives an example to explain how to calculate the load speed:

Assume that F8.06 (Load speed display coefficient) is 2.000 and F8.12 is 2 (2 decimal places). When the running frequency of the inverter is 40.00 Hz, the load speed is  $40.00 \times 2.000 = 80.00$  (display of 2 decimal places).

If the inverter is at the stop state, the load speed is the speed corresponding to the set frequency, namely, "set load speed". If the set frequency is 50.00 Hz, the load speed in the stop state is  $50.00 \times 2.000 = 100.00$  (display of 2 decimal places).

0: 0 decimal place

1: 1 decimal place

2: 2 decimal places

3: 3 decimal places

F8.13	Accumulative power-on time	Range:0~65535h	Default:-
-------	----------------------------	----------------	-----------

It is used to display the accumulative power-on time of the inverter since the delivery. If the time reaches the set power-on time (F4.17), the terminal with the digital output function 24 becomes ON.

F8.14	Accumulative power consumption	Range:0~65535kwh	Default:-
-------	--------------------------------	------------------	-----------

It is used to display the accumulative power consumption of the inverter until now.

**Group F9: Fault and Protection**

F9.00	Motor overload protection selection	Range:0~1	Default:1
-------	-------------------------------------	-----------	-----------

0:The motor overload protective function is disabled. The motor is exposed to potential damage due to overheating. A thermal relay is suggested to be installed between the inverter and the motor.

1:The inverter judges whether the motor is overloaded according to the inverse time-lag curve of the motor overload protection.

F9.01	Motor overload protection gain	Range:0.20~10.00	Default:1.00
-------	--------------------------------	------------------	--------------

The inverse time-lag curve of the motor overload protection is: $220\% * F9.01 * \text{rated motor current}$  (if the load remains at this value for one minute, the inverter reports motor overload fault), or  $150\% * F9.01 * \text{rated motor current}$  (if the load remains at this value for 60 minutes, the inverter reports motor overload fault).

Set F9.01 properly based on the actual overload capacity. If the value of F9.01 is set too large, damage to the motor may result because the motor overheats but the inverter does not report the alarm.

F9.02	Motor overload warning coefficient	Range:50~100	Default:80%
-------	------------------------------------	--------------	-------------

This function is used to give a warning signal to the control system via DO before motor overload protection. This parameter is used to determine the percentage, at which pre-warning is performed before motor overload. The larger the value is, the less advanced the pre-warning will be.

When the accumulative output current of the inverter is greater than the value of the overload inverse time-lag curve multiplied by F9.02, the DO terminal on the inverter allocated with function 6 (Motor overload pre-warning) becomes ON.

F9.03	Overvoltage stall gain	Range:0~100	Default:0
F9.04	Overvoltage stall protective voltage	Range:120%~150%	Default:130%

When the DC bus voltage exceeds the value of F9.04 (Overvoltage stall protective voltage) during deceleration of the inverter, the inverter stops deceleration and keeps the present running frequency. After the bus voltage declines, the inverter continues to decelerate. F9.03 (Overvoltage stall gain) is used to adjust the overvoltage suppression capacity of the inverter. The larger the value is, the greater the overvoltage suppression capacity will be.

In the prerequisite of no overvoltage occurrence, set F9.03 to a small value.

For small-inertia load, the value should be small. Otherwise, the system dynamic response will be slow. For large-inertia load, the value should be large. Otherwise, the suppression result will be poor and an overvoltage fault may occur.

If the overvoltage stall gain is set to 0, the overvoltage stall function is disabled.

F9.05	Overcurrent stall gain	Range:0~100	Default:20
F9.06	Overcurrent stall protective current	Range:100%~200%	Default:150%

When the output current exceeds the overcurrent stall protective current during acceleration/deceleration of the inverter, the inverter stops acceleration/deceleration and keeps the present running frequency. After the output current declines, the inverter continues to accelerate/decelerate.

F9.05 (Overcurrent stall gain) is used to adjust the overcurrent suppression capacity of the

inverter. The larger the value is, the greater the overcurrent suppression capacity will be. In the prerequisite of no overcurrent occurrence, set tF9-05 to a small value.

For small-inertia load, the value should be small. Otherwise, the system dynamic response will be slow. For large-inertia load, the value should be large. Otherwise, the suppression result will be poor and overcurrent fault may occur.

If the overcurrent stall gain is set to 0, the overcurrent stall function is disabled.

F9.07	Short-circuit to ground upon power-on	Range:0~1	Default:1
-------	---------------------------------------	-----------	-----------

0: Disabled

1: Enabled

It is used to determine whether to check the motor is short-circuited to ground at power-on of the inverter. If this function is enabled, the inverter's UVW will have voltage output a while after power-on.

F9.09	Fault auto reset times	Range:0~20	Default:0
-------	------------------------	------------	-----------

It is used to set the times of fault auto resets if this function is used. After the value is exceeded, the inverter will remain in the fault state.

F9.10	X action during fault auto reset	Range:0~1	Default:0
-------	----------------------------------	-----------	-----------

0: Not act

1: Act

It is used to decide whether the DO acts during the fault auto reset if the fault auto reset function is selected.

F9.11	Time interval of fault auto reset	Range:0.1s~100.0s	Default:1.0s
-------	-----------------------------------	-------------------	--------------

It is used to set the waiting time from the alarm of the inverter to fault auto reset.

F9.12	Input phase loss protection/contactor energizing protection selection	Range:0~11	Default:10
-------	---	------------	------------

Unit's digit: Input phase loss protection

Ten's digit: Contactor energizing protection

0: Disabled

1: Enabled

It is used to determine whether to perform input phase loss or contactor energizing protection. When F9.12 = 1, only the three-phase 380V, 018G and above models have the fault.

F9.13	Output phase loss protection selection	Range:0~1	Default:1
-------	--	-----------	-----------

It is used to determine whether to perform output phase loss protection.

0: Disabled

1: Enabled

F9.14	1st fault type	Range:0~99	Default:-
F9.15	2nd fault type	Range:0~99	Default:-
F9.16	3rd (latest) fault type	Range:0~99	Default:-

It is used to record the types of the most recent three faults of the inverter. 0 indicates no fault. For possible causes and solution of each fault, refer to Chapter 7.

F9.17	Frequency upon 3rd fault	Range:—	Default:—
-------	--------------------------	---------	-----------

The frequency upon the last fault.

F9.18	Current upon 3rd fault	Range:—	Default:—
-------	------------------------	---------	-----------

The current upon the last fault.



F9.19	Bus voltage upon 3rd fault	Range:—	Default:—
-------	----------------------------	---------	-----------

The bus voltage upon the last fault.

F9.20	Input terminal status upon 3rd fault	Range:—	Default:—
-------	--------------------------------------	---------	-----------

The input terminal status upon the last fault.The sequence is as follows:

Bit4	Bit3	Bit2	Bit1	Bit0
X5	X4	X3	X2	X1

If a X is ON, the setting is 1. If the X is OFF,the setting is 0.

F9.21	The inverter temperature upon 3rd fault	Range:—	Default:—
-------	---	---------	-----------

The input terminal status upon the last fault.The sequence is as follows:

Bit3	Bit2	Bit1	Bit0
E	R	Y2	Y1

If an output terminal is ON, the setting is 1.If the output terminal is OFF, the setting is 0.

F9.23	Power-on time upon 3rd fault	Range:—	Default:—
-------	------------------------------	---------	-----------

The Power-on time upon the last fault.

F9.24	Running time upon 3rd fault	Range:—	Default:—
-------	-----------------------------	---------	-----------

Running time upon the latest fault.

F9.27	Frequency upon 2nd fault	Range:—	Default:—
F9.28	Current upon 2nd fault	Range:—	Default:—
F9.29	Bus voltage upon 2nd fault	Range:—	Default:—
F9.30	X status upon 2nd fault	Range:—	Default:—
F9.31	The inverter temperature upon 2nd fault	Range:—	Default:—
F9.32	inverter status upon 2nd fault	Range:—	Default:—
F9.33	Power-on time upon 2nd fault	Range:—	Default:—
F9.34	Running time upon 2nd fault	Range:—	Default:—

Same as F9.17~F9.24

F9.37	Frequency upon 1st fault	Range:—	Default:—
F9.38	Current upon 1st fault	Range:—	Default:—
F9.39	Bus voltage upon 1st fault	Range:—	Default:—
F9.40	X status upon 1st fault	Range:—	Default:—
F9.41	The inverter temperature upon 1st fault	Range:—	Default:—
F9.42	inverter status upon 1st fault	Range:—	Default:—
F9.43	Power-on time upon 1st fault	Range:—	Default:—
F9.44	Running time upon 1st fault	Range:—	Default:—

Same as F9.17~F9.24

F9.47	Fault protection action selection 1	Range:0000~2222	Default:0000
-------	-------------------------------------	-----------------	--------------

0: Coast to stop

inverter displays Err \*\*, and directly down

1: Stop according to the stop mode

Drive Show A \*\*, then stop mode, the display Err \*\* after the shutdown.

2: Continue to run

The drive continues to run and display A \*\*, the operating frequency is set by F9.54.

Ten thousand's digit (Communication fault, Err16)	Thousand's digit (External equipment fault, Err15)	Hundred's digit (Power output phase loss, Err13)	Ten's digit (Power input phase loss, Err12)	Unit's digit (Motor overload, Err11)
0: Coast to stop 1: Stop according to the stop mode 2: Continue to run	0: Coast to stop 1: Stop according to the stop mode 2: Continue to run	0: Coast to stop 1: Stop according to the stop mode 2: Continue to run	0: Coast to stop 1: Stop according to the stop mode 2: Continue to run	0: Coast to stop 1: Stop according to the stop mode 2: Continue to run

F9.48	Fault protection action selection 2	Range:0000~2222	Default:0000
-------	-------------------------------------	-----------------	--------------

Ten thousand's digit (Accumulative running time reached)	Thousand's digit: reserved	Hundred's digit: reserved	Ten's digit (EEPROM read-write fault, Err21)	Unit's digit (Encoder fault, Err20)
0: Coast to stop 1: Stop according to the stop mode 2: Continue to run			0: Coast to stop 1: Stop according to the stop mode 2: Continue to run	0: Coast to stop 1: Stop according to the stop mode 2: Continue to run

F9.49	Fault protection action selection 3	Range:0000~2222	Default:0000
-------	-------------------------------------	-----------------	--------------

Ten thousand's digit (PID feedback lost during running, Err31)	Thousand's digit (Load becoming 0, Err30)	Hundred's digit (Accumulative power-on time reached, Err29)	Ten's digit (User-defined fault 2, Err28)	Unit's digit (User-defined fault 1, Err27)
0: Coast to stop 1: Stop according to the stop mode 2: Continue to run	0: Coast to stop 1: Stop according to the stop mode 2: Continue to run at 7% of rated motor frequency and resume to the set frequency if the load recovers	0: Coast to stop 1: Stop according to the stop mode 2: Continue to run	0: Coast to stop 1: Stop according to the stop mode 2: Continue to run	0: Coast to stop 1: Stop according to the stop mode 2: Continue to run

F9.50	Fault protection action selection 4	Range:000~222	Default:000
-------	-------------------------------------	---------------	-------------

Ten's digit (Motor over-speed,Err43)	Unit's digit (Too large speed deviation,Err42)
0: Coast to stop 1:Stop according to the stop mode 2: Continue to run	0: Coast to stop 1:Stop according to the stop mode 2: Continue to run

F9.54	Frequency selection for continuing to run upon fault	Range:0~4	Default:0
-------	--	-----------	-----------

- 0: Current running frequency
- 1: Set frequency
- 2: Frequency upper limit
- 3: Frequency lower limit
- 4: Backup frequency upon abnormality

F9.55	Backup frequency upon abnormality	Range:60.0%~100.0%	Default:100.0%
-------	-----------------------------------	--------------------	----------------

If a fault occurs during the running of the inverter and the handling of fault is set to "Continue to run", the inverter displays A\*\* and continues to run at the frequency set in F9.54.

The setting of F9.55 is a percentage relative to the maximum frequency.

F9.59	Action selection at instantaneous power failure	Range:0~2	Default:0
F9.60	Action pause judging voltage at instantaneous power failure	Range:80.0%~100.0%	Default:90.0%
F9.61	Voltage rally judging time at instantaneous power failure	Range:0.00s~100.00s	Default:0.50s
F9.62	Action judging voltage at instantaneous power failure	Range:60.0%~100.0%	Default:80.0%

Upon instantaneous power failure or sudden voltage dip, the DC bus voltage of the inverter reduces. This function enables the inverter to compensate the DC bus voltage reduction with the load feedback energy by reducing the output frequency so as to keep the inverter running continuously.

If F9.59 = 1, upon instantaneous power failure or sudden voltage dip, the inverter decelerates. Once the bus voltage resumes to normal, the inverter accelerates to the set frequency. If the bus voltage remains normal for the time exceeding the value set in F9.61, it is considered that the bus voltage resumes to normal.

If F9.59 = 2, upon instantaneous power failure or sudden voltage dip, the inverter decelerates to stop.

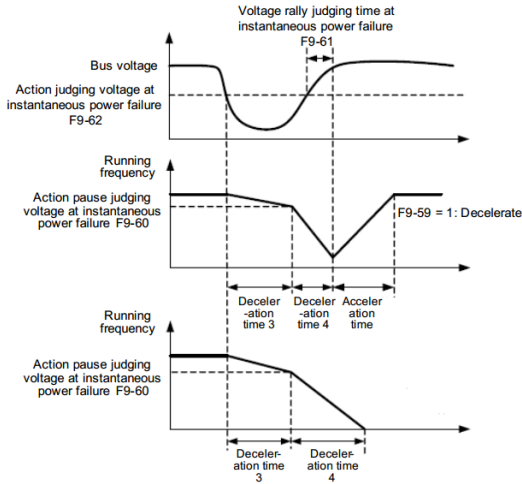

Figure 7.23 inverter action diagram upon instantaneous power failure

F9.63	Protection upon load becoming 0	Range:0~1	Default:0
F9.64	Detection level of load becoming 0	Range:0.0%~100.0%	Default:10.0%
F9.65	Detection time of load becoming 0	Range:0.0s~60.0s	Default:1.0s

If protection upon load becoming 0 is enabled, when the output current of the inverter is lower than the detection level (F9.64) and the lasting time exceeds the detection time (F9.65), the output frequency of the inverter automatically declines to 7% of the rated frequency. During the protection, the inverter automatically accelerates to the set frequency if the load resumes to normal.

F9.67	Over-speed detection value	Range:0.0%~50.0%(maximum frequency)	Default:20.0%
F9.68	Over-speed detection time	Range:0.0s~60.0s	Default:5.0s

This function is valid only when the inverter runs in the CLVC mode.

If the actual motor rotational speed detected by the inverter exceeds the maximum frequency and the excessive value is greater than the value of F9.67 and the lasting time exceeds the value of F9.68, the inverter reports Err43 and acts according to the selected fault protection action.

If the over-speed detection time is 0.0s, the over-speed detection function is disabled

F9.69	Detection value of too large speed deviation	Range:0.0%~50.0%(maximum frequency)	Default:20.0%
F9.70	Detection time of too large speed deviation	Range:0.0s~60.0s	Default:0.0s

This function is valid only when the inverter runs in the CLVC mode.

If the inverter detects the deviation between the actual motor rotational speed detected by the inverter and the set frequency is greater than the value of F9.69 and the lasting time exceeds the value of F9.70, the inverter reports Err42 and according to the selected fault protection action.

If F9.70 (Detection time of too large speed deviation) is 0.0s, this function is disabled.

**Group FA: Process Control PID Function**

FA.00	PID setting source	Range:0~6	Default:0
FA.01	PID digital setting	Range:0.0%~100.0%	Default:50.0%

FA.00 is used to select the channel of target process PID setting. The PID setting is a relative value and ranges from 0.0% to 100.0%. The PID feedback is also a relative value. The purpose of PID control is to make the PID setting and PID feedback equal.

- 0: FA-01
- 1: AI1
- 2: AI2
- 3: AI3
- 5: Communication setting
- 6: Multi-reference

FA.02	PID feedback source	Range:0~8	Default:0
-------	---------------------	-----------	-----------

This parameter is used to select the feedback signal channel of process PID.

- 0: AI1
- 1: AI2
- 2: AI3
- 3: AI1 – AI2
- 4: Pulse setting (DI5)
- 5: Communication setting
- 6: AI1 + AI2
- 7: MAX (AI1, AI2)
- 8: MIN (AI1, AI2)

FA.03	PID action direction	Range:0~1	Default:0
-------	----------------------	-----------	-----------

0: Forward action

When the feedback value is smaller than the PID setting, the inverter's output frequency rises. For example, the winding tension control requires forward PID action.

1: Reverse action

When the feedback value is smaller than the PID setting, the inverter's output frequency reduces. For example, the unwinding tension control requires reverse PID action.

Note that this function is influenced by the DI function 35 "Reverse PID action direction".

FA.04	PID setting feedback range	Range:0~65535	Default:1000
-------	----------------------------	---------------	--------------

This parameter is a non-dimensional unit. It is used for PID setting display (H0.14) and PID feedback display (H0.15).

Relative value 100% of PID setting feedback corresponds to the value of FA.04. If FA-04 is set to 2000 and PID setting is 100.0%, the PID setting display (H0.14) is 2000.

FA.05	Proportional gain Kp1	Range:0.0~100.0	Default:20
FA.06	Integral time Ti1	Range:0.01s~10.00s	Default:2.00s
FA.07	Differential time Td1	Range:0.000s~10.000s	Default:0.000s

Proportional gain Kp1:

It decides the regulating intensity of the PID regulator. The higher the Kp1 is, the larger the regulating intensity is. The value 100.0 indicates when the deviation between PID feedback and PID setting is 100.0%, the adjustment amplitude of the PID regulator on the output

frequency reference is the maximum frequency.

Integral time Ti1:

It decides the integral regulating intensity. The shorter the integral time is, the larger the regulating intensity is. When the deviation between PID feedback and PID setting is 100.0%, the integral regulator performs continuous adjustment for the time set in FA.06. Then the adjustment amplitude reaches the maximum frequency.

Differential time Td1:

It decides the regulating intensity of the PID regulator on the deviation change. The longer the differential time is, the larger the regulating intensity is. Differential time is the time within which the feedback value change reaches 100.0%, and then the adjustment amplitude reaches the maximum frequency.

FA.08	Cut-off frequency of PID reverse rotation	Range:0.00 to maximum frequency	Default:2.00Hz
-------	---	---------------------------------	----------------

In some situations, only when the PID output frequency is a negative value (inverter reverse rotation), PID setting and PID feedback can be equal. However, too high reverse rotation frequency is prohibited in some applications, and FA-08 is used to determine the reverse rotation frequency upper limit.

FA.09	PID deviation limit	Range:0.0%~100.0%	Default:0.0%
-------	---------------------	-------------------	--------------

If the deviation between PID feedback and PID setting is smaller than the value of FA.09, PID control stops. The small deviation between PID feedback and PID setting will make the output frequency stabilize, effective for some closed-loop control applications.

FA.10	PID differential limit	Range:0.00%~100.00%	Default:0.10%
-------	------------------------	---------------------	---------------

It is used to set the PID differential output range. In PID control, the differential operation may easily cause system oscillation. Thus, the PID differential regulation is restricted to a small range.

FA.11	PID setting change time	Range:0.00~650.00s	Default:0.00s
-------	-------------------------	--------------------	---------------

The PID setting change time indicates the time required for PID setting changing from 0.0% to 100.0%. The PID setting changes linearly according to the change time, reducing the impact caused by sudden setting change on the system.

FA.12	PID feedback filter time	Range:0.00~60.00s	Default:0.00s
FA.13	PID output filter time	Range:0.00~60.00s	Default:0.00s

FA.12 is used to filter the PID feedback, helping to reduce interference on the feedback but slowing the response of the process closed-loop system.

FA.13 is used to filter the PID output frequency, helping to weaken sudden change of the inverter output frequency but slowing the response of the process closed-loop system.

FA.15	Proportional gain Kp2	Range:0.0~100.0	Default:20.0
FA.16	Integral time Ti2	Range:0.01s~10.00s	Default:2.00s
FA.17	Differential time Td2	Range:0.000s~10.000s	Default:0.000s
FA.18	PID parameter switchover condition	Range:0~2	Default:0
FA.19	PID parameter	Range:0.0%~FA.20	Default:20.0%

	switchover deviation 1		
FA.20	PID parameter switchover deviation 2	Range:FA.19~100.0%	Default:80.0%

In some applications, PID parameters switchover is required when one group of PID parameters cannot satisfy the requirement of the whole running process.

These parameters are used for switchover between two groups of PID parameters.

Regulator parameters FA.15 to FA.17 are set in the same way as FA.05 to FA.07.

The switchover can be implemented either via a DI terminal or automatically implemented based on the deviation.

If you select switchover via a DI terminal, the DI must be allocated with function 41 "PID parameter switchover". If the X is OFF, group 1 (FA.05 to FA.07) is selected. If the X is ON, group 2 (FA.15 to FA.17) is selected.

If you select automatic switchover, when the absolute value of the deviation between PID feedback and PID setting is smaller than the value of FA.19, group 1 is selected. When the absolute value of the deviation between PID feedback and PID setting is higher than the value of FA.20, group 2 is selected. When the deviation is between FA.19 and FA.20, the PID parameters are the linear interpolated value of the two groups of parameter values.

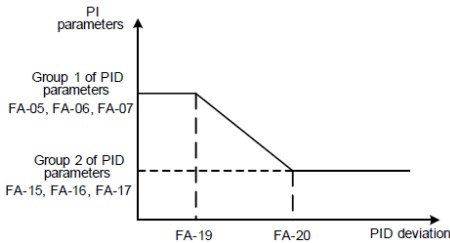

Figure7.24 PID parameters switchover

FA.21	PID initial value	Range:0.0%~100.0%	Default:0.0%
FA.22	PID initial value holding time	Range:0.00~650.00s	Default:0.00s

When the inverter starts up, the PID starts closed-loop algorithm only after the PID output is fixed to the PID initial value (FA.21) and lasts the time set in FA.22.

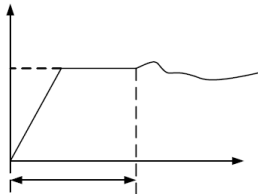

Figure7.25 PID initial value function

FA.23	Maximum deviation between two PID outputs in forward direction	Range:0.00%~100.00%	Default:1.00%
FA.24	Maximum deviation	Range:0.00%~100.00%	Default:1.00%

	between two PID outputs in reverse direction		
--	--	--	--

This function is used to limit the deviation between two PID outputs (2 ms per PID output) to suppress the rapid change of PID output and stabilize the running of the inverter.

FA.23 and FA.24 respectively correspond to the maximum absolute value of the output deviation in forward direction and in reverse direction.

FA.25	PID integral property	Range:11	Default:00
-------	-----------------------	----------	------------

Unit's digit (Integral separated)

0: Invalid

1: Valid

If it is set to valid, , the PID integral operation stops when the X allocated with function 38 "PID integral pause" is ON In this case, only proportional and differential operations take effect.

If it is set to invalid, integral separated remains invalid no matter whether the X allocated with function 38 "PID integral pause" is ON or not.

Ten's digit (Whether to stop integral operation when the output reaches the limit)

0: Continue integral operation

1: Stop integral operation

Whether to stop integral operation when the output reaches the limit

If "Stop integral operation" is selected, the PID integral operation stops, which may help to reduce the PID overshoot.

FA.26	Detection value of PID feedback loss	Range:0.0%: Not judging feedback loss 0.1% - 100.0%	Default:0.0%
FA.27	Detection time of PID feedback loss	Range:0.0s~20.0s	Default:0.0s

These parameters are used to judge whether PID feedback is lost.

If the PID feedback is smaller than the value of FA.26 and the lasting time exceeds the value of FA.27, the inverter reports Err31 and acts according to the selected fault protection action.

FA.28	PID operation at stop	0: No PID operation at stop 1: PID operation at stop	Default:0
-------	-----------------------	---	-----------

It is used to select whether to continue PID operation in the state of stop. Generally, the PID operation stops when the inverter stops.

### Group FB: Swing Frequency, Fixed Length ,Count and Torque Control Parameters

The swing frequency function is applied to the textile and chemical fiber fields and the applications where traversing and winding functions are required.

The swing frequency function indicates that the output frequency of the inverter swings up and down with the set frequency as the center. The trace of running frequency at the time axis is shown in the following Figure .



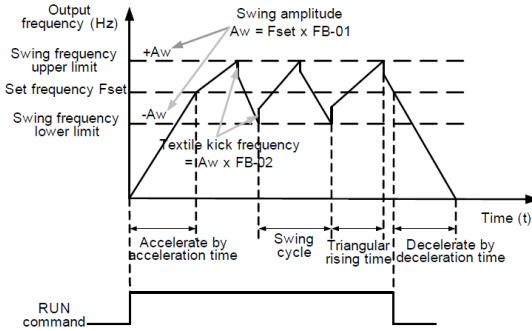

Figure 7.26 Swing frequency control

Fb.00	Swing frequency setting mode	Range:0~1	Default:0
-------	------------------------------	-----------	-----------

This parameter is used to select the base value of the swing amplitude.

0: Relative to the central frequency (F0.07 frequency source selection)

It is variable swing amplitude system. The swing amplitude varies with the central frequency (set frequency).

1: Relative to the maximum frequency (F0.10 maximum output frequency)

It is fixed swing amplitude system. The swing amplitude is fixed.

Fb.01	Swing frequency amplitude	Range:0.0%~100.0%	Default:0.0%
Fb.02	Jump frequency amplitude	Range:0.0%~50.0%	Default:0.0%

This parameter is used to determine the swing amplitude and jump frequency amplitude. The swing frequency is limited by the frequency upper limit and frequency lower limit.

- If relative to the central frequency (Fb.00 = 0), the actual swing amplitude AW is the calculation result of F0.07 (Frequency source selection) multiplied by Fb.01.

- If relative to the maximum frequency (Fb.00 = 1), the actual swing amplitude AW is the calculation result of F0.10 (Maximum frequency) multiplied by Fb.01.

Jump frequency = Swing amplitude AW \* Fb.02 (Jump frequency amplitude).

- If relative to the central frequency (Fb.00 = 0), the jump frequency is a variable value.

- If relative to the maximum frequency (Fb.00 = 1), the jump frequency is a fixed value.

The swing frequency is limited by the frequency upper limit and frequency lower limit.

Fb.03	Swing frequency cycle	Range:0.1s~3000.0s	Default:10.0s
Fb.04	Triangular wave rising time coefficient	Range:0.1%~100.0%	Default:50.0%

Fb.03 specifies the time of a complete swing frequency cycle.

Fb.04 specifies the time percentage of triangular wave rising time to Fb.03 (Swing frequency cycle).

- Triangular wave rising time = Fb.03 (Swing frequency cycle) \* Fb.04 (Triangular wave rising time coefficient, unit: s)

- Triangular wave falling time = Fb.03 (Swing frequency cycle) \* (1 - Fb.04 Triangular

wave rising time coefficient ,unit: s)

Fb.05	Set length	Range:0m~65535m	Default:1000m
Fb.06	Actual length	Range:0m~65535m	Default:0m
Fb.07	Number of pulses per meter	Range:0.1~6553.5	Default:100.0

The preceding parameters are used for fixed length control.

The length information is collected by X terminals. Fb.06 (Actual length) is calculated by dividing the number of pulses collected by the X terminal by Fb.07 (Number of pulses each meter).

When the actual length Fb.06 exceeds the set length in Fb.05, the output terminal allocated with function 10 (Length reached) becomes ON.

During the fixed length control, the length reset operation can be performed via the X terminal allocated with function 28. For details, see the descriptions of F4.00 to F4.09.

Allocate corresponding X terminal with function 27 (Length count input) in applications. If the pulse frequency is high, X5 must be used.

Fb.08	Set count value	Range:1~65535	Default:1000
Fb.09	Designated count value	Range:1~65535	Default:1000

The count value needs to be collected by X terminal. Allocate the corresponding X terminal with function 25 (Counter input) in applications. If the pulse frequency is high, X5 must be used.

When the count value reaches the set count value (Fb.08), the output terminal allocated with function 8 (Set count value reached) becomes ON. Then the counter stops counting.

When the counting value reaches the designated counting value (Fb.09), the output terminal allocated with function 9 (Designated count value reached) becomes ON. Then the counter continues to count until the set count value is reached.

Fb.09 should be equal to or smaller than Fb.08.

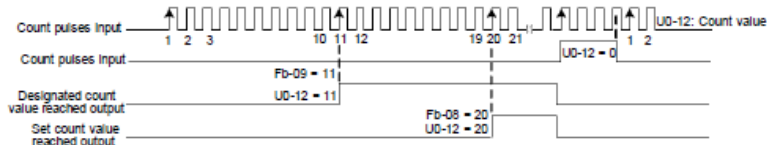

Figure7.27 Reaching the set count value and designated count value

Fb.10	Speed/Torque control selection	Range:0~1	Default:0
-------	--------------------------------	-----------	-----------

It is used to select the inverter's control mode: speed control or torque control.

0: speed control

1: torque control, when using this mode, you need to set F0.01 to 0.

The JT580 provides DI terminals with two torque related functions, function 29 (Torque control prohibited) and function 46 (Speed control/Torque control switchover). The two DI terminals need to be used together with A0.00 to implement speed control/torque control switchover. If the DI terminal allocated with function 46 (Speed control/Torque control switchover) is OFF, the control mode is determined by Fb.00. If the DI terminal allocated with function 46 is ON, the control mode is reverse to the value of Fb.00.

However, if the DI terminal with function 29 (Torque control prohibited) is ON, the inverter is fixed to run in the speed control mode.

Fb.11	Torque setting source in torque control	Range:0~7	Default:0
Fb.12	Torque digital setting in torque control	Range:-200.0%~200.0%	Default:150.0%

Fb.11 is used to set the torque setting source. There are a total of eight torque setting sources.

The torque setting is a relative value. 100.0% corresponds to the inverter's rated torque. The setting range is -200.0% to 200.0%, indicating the inverter's maximum torque is twice of the inverter's rated torque.

If the torque setting is positive, the inverter rotates in forward direction. If the torque setting is negative, the inverter rotates in reverse direction.

- 1: Digital setting (Fb.12)

The target torque directly uses the value set in Fb.12.

- 2: AI1

- 3: AI2

- 4: AI3

- 5: Pulse setting (DI5)

- 6: Communication setting

The target torque is set by means of communication.

The data format is -100.00% to 100.00%. 100% corresponds to the value of Fb.12.

Fb.13	Forward maximum frequency in torque control	Range:0.00Hz to maximum frequency	Default:50.00Hz
Fb.14	Reverse maximum frequency in torque control	Range:0.00Hz to maximum frequency	Default:50.00Hz

Two parameters are used to set the maximum frequency in forward or reverse rotation in torque control mode.

In torque control, if the load torque is smaller than the motor output torque, the motor's rotational speed will rise continuously. To avoid runaway of the mechanical system, the motor maximum rotating speed must be limited in torque control.

You can implement continuous change of the maximum frequency in torque control dynamically by controlling the frequency upper limit.

Fb.15	Acceleration time in torque control	Range:0.00s~65000s	Default:0.00s
Fb.16	Deceleration time in torque control	Range:0.00s~65000s	Default:0.00s

In torque control, the difference between the motor output torque and the load torque determines the speed change rate of the motor and load. The motor rotational speed may change quickly and this will result in noise or too large mechanical stress. The setting of acceleration/deceleration time in torque control makes the motor rotational speed change softly.

However, in applications requiring rapid torque response, set the acceleration/deceleration

time in torque control to 0.00s. For example, two inverters are connected to drive the same load. To balance the load allocation, set one inverter as master in speed control and the other as slave in torque control. The slave receives the master's output torque as the torque command and must follow the master rapidly. In this case, the acceleration/deceleration time of the slave in torque control is set to 0.0s.

## Group FC: Multi-Reference and Simple PLC Function Parameters

FC.00	Reference 0	Range:-100.0%~100.0%	Default:0.0%
FC.01	Reference 1	Range:-100.0%~100.0%	Default:0.0%
FC.02	Reference 2	Range:-100.0%~100.0%	Default:0.0%
FC.03	Reference 3	Range:-100.0%~100.0%	Default:0.0%
FC.04	Reference 4	Range:-100.0%~100.0%	Default:0.0%
FC.05	Reference 5	Range:-100.0%~100.0%	Default:0.0%
FC.06	Reference 6	Range:-100.0%~100.0%	Default:0.0%
FC.07	Reference 7	Range:-100.0%~100.0%	Default:0.0%
FC.08	Reference 8	Range:-100.0%~100.0%	Default:0.0%
FC.09	Reference 9	Range:-100.0%~100.0%	Default:0.0%
FC.10	Reference10	Range:-100.0%~100.0%	Default:0.0%
FC.11	Reference11	Range:-100.0%~100.0%	Default:0.0%
FC.12	Reference12	Range:-100.0%~100.0%	Default:0.0%
FC.13	Reference13	Range:-100.0%~100.0%	Default:0.0%
FC.14	Reference14	Range:-100.0%~100.0%	Default:0.0%
FC.15	Reference15	Range:-100.0%~100.0%	Default:0.0%

Multi-reference can be the setting source of frequency, V/F separated voltage and process PID. The multi-reference is relative value and ranges from -100.0% to 100.0%.

As frequency source, it is a percentage relative to the maximum frequency. As V/F separated voltage source, it is a percentage relative to the rated motor voltage. As process PID setting source, it does not require conversion.

Multi-reference can be switched over based on different states of DI terminals. For details, see the descriptions of group F2.

FC.16	Simple PLC running mode	Range:0~2	Default:0
-------	-------------------------	-----------	-----------

0: Stop after the inverter runs one cycle

1: Keep final values after the inverter runs one cycle

2: Repeat after the inverter runs one cycle

When simple PLC is used as the frequency source, whether parameter values of FC.00 to FC.15 are positive or negative determines the running direction. If the parameter values are negative, it indicates that the inverter runs in reverse direction.

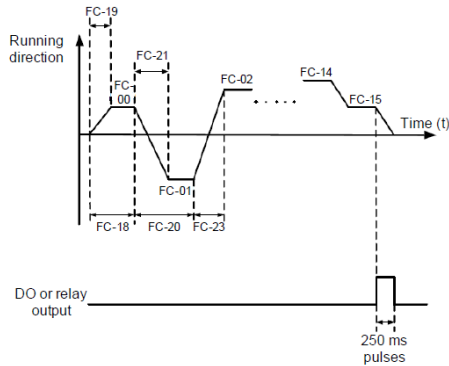

Figure7.28 Simple PLC when used as frequency source

FC.17	Simple PLC retentive selection	Range:00~11	Default:00
-------	--------------------------------	-------------	------------

PLC retentive upon power failure indicates that the inverter memorizes the PLC running moment and running frequency before power failure and will continue to run from the memorized moment after it is powered on again. If the unit's digit is set to 0, the inverter restarts the PLC process after it is powered on again.

PLC retentive upon stop indicates that the inverter records the PLC running moment and running frequency upon stop and will continue to run from the recorded moment after it starts up again. If the ten's digit is set to 0, the inverter restarts the PLC process after it starts up again.

FC.18	Running time of simple PLC reference 0	Range:0.0s (h) ~6553.5s (h)	Default:0.0s (h)
FC.19	Acceleration/deceleration time of simple PLC reference 0	Range:0~3	Default:0
FC.20	Running time of simple PLC reference 1	Range:0.0s (h) ~6553.5s (h)	Default:0.0s (h)
FC.21	Acceleration/deceleration time of simple PLC reference 1	Range:0~3	Default:0
FC.22	Running time of simple PLC reference 2	Range:0.0s (h) ~6553.5s (h)	Default:0.0s (h)
FC.23	Acceleration/deceleration time of simple PLC reference 2	Range:0~3	Default:0
FC.24	Running time of simple PLC reference 3	Range:0.0s (h) ~6553.5s (h)	Default:0.0s (h)
FC.25	Acceleration/deceleration time of simple PLC reference 3	Range:0~3	Default:0
FC.26	Running time of simple PLC reference 4	Range:0.0s (h) ~6553.5s (h)	Default:0.0s (h)
FC.27	Acceleration/deceleration time of simple PLC reference 4	Range:0~3	Default:0
FC.28	Running time of simple PLC reference 5	Range:0.0s (h) ~6553.5s (h)	Default:0.0s (h)
FC.29	Acceleration/deceleration time of simple PLC reference 5	Range:0~3	Default:0
FC.30	Running time of simple PLC	Range:0.0s (h)	Default:0.0s (h)

	reference 6	~6553.5s (h)	
FC.31	Acceleration/deceleration time of simple PLC reference 6	Range:0~3	Default:0
FC.32	Running time of simple PLC reference 7	Range:0.0s (h) ~6553.5s (h)	Default:0.0s (h)
FC.33	Acceleration/deceleration time of simple PLC reference 7	Range:0~3	Default:0
FC.34	Running time of simple PLC reference 8	Range:0.0s (h) ~6553.5s (h)	Default:0.0s (h)
FC.35	Acceleration/deceleration time of simple PLC reference 8	Range:0~3	Default:0
FC.36	Running time of simple PLC reference 9	Range:0.0s (h) ~6553.5s (h)	Default:0.0s (h)
FC.37	Acceleration/deceleration time of simple PLC reference 9	Range:0~3	Default:0
FC.38	Running time of simple PLC reference 10	Range:0.0s (h) ~6553.5s (h)	Default:0.0s (h)
FC.39	Acceleration/deceleration time of simple PLC reference 10	Range:0~3	Default:0
FC.40	Running time of simple PLC reference 11	Range:0.0s (h) ~6553.5s (h)	Default:0.0s (h)
FC.41	Acceleration/deceleration time of simple PLC reference 11	Range:0~3	Default:0
FC.42	Running time of simple PLC reference 12	Range:0.0s (h) ~6553.5s (h)	Default:0.0s (h)
FC.43	Acceleration/deceleration time of simple PLC reference 12	Range:0~3	Default:0
FC.44	Running time of simple PLC reference 13	Range:0.0s (h) ~6553.5s (h)	Default:0.0s (h)
FC.45	Acceleration/ deceleration time of simple PLC reference 13	Range:0~3	Default:0
FC.46	Running time of simple PLC reference 14	Range:0.0s (h) ~6553.5s (h)	Default:0.0s (h)
FC.47	Acceleration/deceleration time of simple PLC reference 14	Range:0~3	Default:0
FC.48	Running time of simple PLC reference 15	Range:0.0s (h) ~6553.5s (h)	Default:0.0s (h)
FC.49	Acceleration/deceleration time of simple PLC reference 15	Range:0~3	Default:0
FC.50	Time unit of simple PLC running	Range:0~1	Default:0
FC.51	Reference 0 source	Range:0~6	Default:0

It determines the setting channel of reference 0. You can perform convenient switchover between the setting channels. When multi-reference or simple PLC is used as frequency source, the switchover between two frequency sources can be realized easily.

### Group FD: User-defined Parameters

See above description.

### Group FE:Quick Menu Parameters

FE.00	Quick Menu 0	F0.00~FF.xx	Default:F0.10
-------	--------------	-------------	---------------

FE.01	Quick Menu 1		Default:F0.02
FE.02	Quick Menu 2		Default:F0.03
FE.03	Quick Menu 3		Default:F0.07
FE.04	Quick Menu 4		Default:F0.08
FE.05	Quick Menu 5		Default:F0.17
FE.06	Quick Menu 6		Default:F0.18
FE.07	Quick Menu 7		Default:F3.00
FE.08	Quick Menu 8		Default:F3.01
FE.09	Quick Menu 9		Default:F4.00
FE.10	Quick Menu 10		Default:F4.01
FE.11	Quick Menu 11		Default:F4.02
FE.12	Quick Menu 12		Default:F5.04
FE.13	Quick Menu 13		Default:F5.07
FE.14	Quick Menu 14		Default:F6.00
FE.15	Quick Menu 15		Default:F6.10
FE.16	Quick Menu 16		Default:F0.00
FE.17	Quick Menu 17		Default:F0.00
FE.18	Quick Menu 18		Default:F0.00
FE.19	Quick Menu 19		Default:F0.00
FE.20	Quick Menu 20		Default:F0.00
FE.21	Quick Menu 21		Default:F0.00
FE.22	Quick Menu 22		Default:F0.00
FE.23	Quick Menu 23		Default:F0.00
FE.25	Quick Menu 24		Default:F0.00
FE.26	Quick Menu 24		Default:F0.00
FE.27	Quick Menu 24		Default:F0.00
FE.28	Quick Menu 24		Default:F0.00
FE.29	Quick Menu 24		Default:F0.00

FE is user-defined parameter group. You can select the required parameters from all JT580 functions codes and add them into this group, convenient for view and modification.

Group FE provides a maximum of 30 user-defined parameters. If "FE.00" is displayed, it indicates that group FE is null. After you enter Quick Menu mode, the displayed parameters are defined by FE.00 to FE.29 and the sequence is consistent with that in group FE.

**Group P0:Analog Four Points Offset Parameters**

P0.00	AI curve 4 minimum input	Range:-10.00V~P0.02	Default:0.00V
P0.01	Corresponding setting of AI curve 4 minimum input	Range:-100.0%~+100.0%	Default:0.0%
P0.02	AI curve 4 inflexion 1 input	Range:P0.00~P0.04	Default:3.00V
P0.03	Corresponding setting of AI curve 4 inflexion 1 input	Range:-100.0%~+100.0%	Default:30.0%
P0.04	AI curve 4 inflexion 1 input	Range:P0.02~P0.06	Default:6.00V
P0.05	Corresponding setting of AI curve 4 inflexion 1 input	Range:-100.0%~+100.0%	Default:60.0%
P0.06	AI curve 4 maximum input	Range:P0.06~+10.00V	Default:10.00V
P0.07	Corresponding setting of AI curve 4 maximum input	Range:-100.0%~+100.0%	Default:100.0%
P0.08	AI curve 5 minimum input	Range:-10.00V~P0.10	Default:-10.00V

P0.09	Corresponding setting of AI curve 5 minimum input	Range:-100.0%~+100.0%	Default:-100.0%
P0.10	AI curve 5 inflexion 1 input	Range:P0.08~P0.12	Default:-3.00V
P0.11	Corresponding setting of AI curve 5 inflexion 1 input	Range:-100.0%~+100.0%	Default:-30.0%
P0.12	AI curve 5 inflexion 1 input	Range:P0.10~P0.14	Default:3.00V
P0.13	Corresponding setting of AI curve 5 inflexion 1 input	Range:-100.0%~+100.0%	Default:30.0%
P0.14	AI curve 5 maximum input	Range:P0.12~+10.00V	Default:10.00V
P0.15	Corresponding setting of AI curve 5 maximum input	Range:-100.0%~+100.0%	Default:100.0%

The function of curve 4 and curve 5 is similar to that curve 1 to curve 3, but curve 1 to curve 3 are lines, and curve 4 and curve 5 are 4-point curves, implementing more flexible corresponding relationship. The schematic diagram of curve 4 and curve 5 is shown in the following Figure .

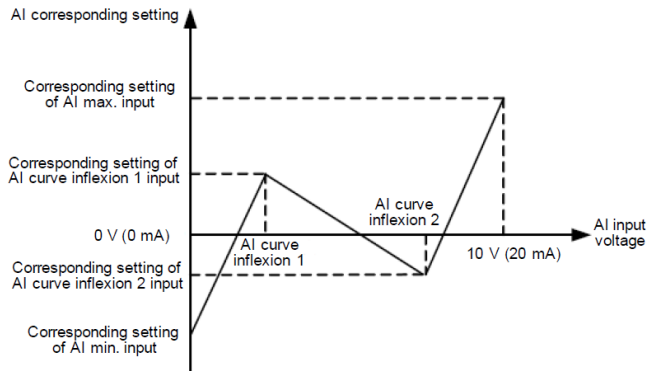

Figure 7.29 Schematic diagram curve 4 and curve 5

When setting curve 4 and curve 5, note that the curve's minimum input voltage, inflexion 1 voltage, inflexion 2 voltage and maximum voltage must be in increment order.

F2.33 (AI curve selection) is used to select curve for AI1 to AI3.

P0.24	Jump point of AI1 input corresponding setting	Range:-100.0%~100.0%	Default:0.0%
P0.25	Jump amplitude of AI1 input corresponding setting	Range:0.0%~100.0%	Default:0.5%
P0.26	Jump point of AI2 input corresponding setting	Range:-100.0%~100.0%	Default:0.0%
P0.27	Jump amplitude of AI2 input corresponding setting	Range:0.0%~100.0%	Default:0.5%
P0.28	Jump point of AI3 input corresponding setting	Range:-100.0%~100.0%	Default:0.0%
P0.29	Jump amplitude of AI3 input corresponding setting	Range:0.0%~100.0%	Default:0.5%

The AI terminals (AI1 to AI3) of the JT580 all support the corresponding setting jump function, which fixes the AI input corresponding setting at the jump point when AI input corresponding setting jumps around the jump range.



For example, AI1 input voltage jumps around 5.00 V and the jump range is 4.90~5.10 V. AI1 minimum input 0.00 V corresponds to 0.0% and maximum input 10.00 V corresponds to 100.0%. The detected AI1 input corresponding setting varies between 49.0% and 51.0%.

If you set P0.24 to 50.0% and P0.25 to 1.0%, then the obtained AI1 input corresponding setting is fixed to 50.0%, eliminating the fluctuation effect.

## Group P1: Analog Calibration Parameters

P1.00	AI1 measured voltage 1	Range:0.500V~4.000V	Factory corrected
P1.01	AI1 displayed voltage 1	Range:0.500V~4.000V	Factory corrected
P1.02	AI1 measured voltage 2	Range:6.000V~9.999V	Factory corrected
P1.03	AI1 displayed voltage 2	Range:6.000V~9.999V	Factory corrected
P1.04	AI2 measured voltage 1	Range:0.500V~4.000V	Factory corrected
P1.05	AI2 displayed voltage 1	Range:0.500V~4.000V	Factory corrected
P1.06	AI2 measured voltage 2	Range:6.000V~9.999V	Factory corrected
P1.07	AI2 displayed voltage 2	Range:6.000V~9.999V	Factory corrected
P1.08	AI3 measured voltage 1	Range:0.500V~4.000V	Factory corrected
P1.09	AI3 displayed voltage 1	Range:0.500V~4.000V	Factory corrected
P1.10	AI3 measured voltage 2	Range:6.000V~9.999V	Factory corrected
P1.11	AI3 displayed voltage 2	Range:6.000V~9.999V	Factory corrected

These parameters are used to correct the AI to eliminate the impact of AI zero offset and gain.

They have been corrected upon delivery. When you resume the factory values, these parameters will be restored to the factory-corrected values. Generally, you need not perform correction in the applications.

Measured voltage indicates the actual output voltage value measured by instruments such as the multimeter. Displayed voltage indicates the voltage display value sampled by the inverter. For details, refer to H0.31, H0.32 and H0.33.

During correction, send two voltage values to each AI terminal, and save the measured values and displayed values to the function codes P1.00 to P1.11. Then the inverter will automatically perform AI zero offset and gain correction.

If the input voltage and the actual voltage sampled by the inverter are inconsistent, perform correction on site. Take AI1 as an example. The on-site correction is as follows:

- 1) Send a voltage signal (approximately 2 V) to AI1.
- 2) Measure the AI1 voltage and save it to P1.00.
- 3) View the displayed value of H0.31 and save the value to P1.01.
- 4) Send a voltage signal (approximately 8 V) to AI1.
- 5) Measure AI1 voltage and save it to P1.02.
- 6) View the displayed value of H0.31 and save the value to P1.03.

At correction of AI2 and AI3, the actually sampled voltage is respectively queried in H0.32 and H0.33.

For AI1 and AI2, 2 V and 8 V are suggested as the correction voltages. For AI3, -8 V and 8 V are suggested.

P1.12	AO1 target voltage 1	Range:0.500V~4.000V	Factory corrected
P1.13	AO1 measured voltage 1	Range:0.500V~4.000V	Factory corrected
P1.14	AO1 target voltage 2	Range:6.000V~9.999V	Factory corrected
P1.15	AO1 measured voltage 2	Range:6.000V~9.999V	Factory corrected
P1.16	AO2 target voltage 1	Range:0.500V~4.000V	Factory corrected

P1.17	AO2 measured voltage 1	Range:0.500V~4.000V	Factory corrected
P1.18	AO2 target voltage 2	Range:6.000V~9.999V	Factory corrected
P1.19	AO2 measured voltage 2	Range:6.000V~9.999V	Factory corrected
P1.20	AI1 filtering dead zone	Range:0~255	Default:0
P1.21	AI2 filtering dead zone	Range:0~255	Default:0
P1.22	AI3 filtering dead zone	Range:0~255	Default:66

These parameters are used to correct the AO.

They have been corrected upon delivery. When you resume the factory values, these parameters will be restored to the factory-corrected values. You need not perform correction in the applications.

Target voltage indicates the theoretical output voltage of the inverter. Measured voltage indicates the actual output voltage value measured by instruments such as the multimeter.

P1.20	AI1 filtering dead zone	Range:0~255	Default:0
P1.21	AI2 filtering dead zone	Range:0~255	Default:0
P1.22	AI3 filtering dead zone	Range:0~255	Default:66

The group function is used to eliminate analog input jitter.the larger the set value, analog jitter smaller, but the larger the error.

### Group H0: Monitoring Parameters

H0.00	Running frequency (Hz)	0.01Hz
H0.01	Set frequency (Hz)	0.01Hz

These two parameters display the absolute value of theoretical running frequency and set frequency. For the actual output frequency of the inverter, see H0.19.

H0.02	Output current (A)	0.01A
-------	--------------------	-------

It displays the inverter's output current in the running state.

H0.03	Output voltage (V)	1V
-------	--------------------	----

It displays the inverter's output voltage in the running state

H0.04	Output power (kW)	0.1kW
-------	-------------------	-------

It displays the inverter's output power in the running state.

H0.05	Output torque (%)	0.1%
-------	-------------------	------

It displays the inverter's output torque in the running state

H0.06	Bus voltage (V)	0.1V
-------	-----------------	------

It displays the inverter's bus voltage.

H0.07	X input state1	1
-------	----------------	---

It displays the current state of X terminals,The corresponding relationship between bits and Xs is described in the following table.

Bit4	Bit3	Bit2	Bit1	Bit0
X5	X4	X3	X2	X1

H0.08	Monitor the IO expansion card	1
-------	-------------------------------	---

Show the current IO extension card X terminal input status values. The correspondence is the following

Bit4	Bit3	Bit2	Bit1	Bit0
X10	X9	X8	X7	X6

H0.09	DO output state	1
-------	-----------------	---

It displays the current state of DO terminals,The corresponding relationship between bits and Xs is described in the following table.

Bit3	Bit2	Bit1	Bit0
R2	R1	Y2	Y1

H0.10	AI1 voltage (V)	0.01V
H0.11	AI2 voltage (V)	0.01V
H0.12	AI3 voltage (V)	0.01V

Show current AI1, AI2 and AI3( keyboard potentiometer )voltage (corrected)

H0.13	Input pulse frequency (kHz)	0.01kHz
-------	-----------------------------	---------

The input current 1mA correspond to 0.5V.

It displays the X5 high-speed pulse sampling frequency. Its minimum unit is 0.01 Hz.

H0.14	PID setting	1
H0.15	PID feedback	1
H0.16	PID output	1

They display the PID setting value and PID feedback value.

PID setting = PID setting (percentage) \*FA-04

PID feedback = PID feedback (percentage) \* FA-04

PID output= PID output (percentage)\*FA.04

H0.17	Load speed	1
-------	------------	---

Displayed value see F8.12

H0.18	Main frequency	0.01Hz
-------	----------------	--------

It displays the setting of main frequency

H0.19	Auxiliary frequency	0.01Hz
-------	---------------------	--------

It displays the setting of auxiliary frequency

H0.20	Feedback speed (unit:0.1Hz)	0.1Hz
-------	-----------------------------	-------

It displays the actual output frequency of the inverter.

H0.21	Count value	1
-------	-------------	---

It displays the current count value.Please refer to Fb.08,Fb.09

H0.22	Length value	1
-------	--------------	---

It displays the current length value.Please refer to Fb.05~Fb.07

H0.23	Linear speed	1m/Min
-------	--------------	--------

It displays the current linear speed.Please refer to Fb.06,Fb.07

H0.24	Accumulative power-on time	1Min
-------	----------------------------	------

It displays the current accumulative power-on time

H0.25	Accumulative running time	0.1Min
-------	---------------------------	--------

It displays the current accumulative running time

H0.26	Motor overload count	1
-------	----------------------	---

It displays the current overload degree

H0.27	Motor output current percentage	0.01%
-------	---------------------------------	-------

It displays the output current percentage (Relative to motor rated current)

H0.28	Remaining operating time	0.1Min
-------	--------------------------	--------

It displays the remaining operating time when it is timing running.

The description of timing running is refer toF4.42~F4.44.

H0.29	PLC stage	1
-------	-----------	---

It displays the current PLC stage

H0.30	Communication setting value	0.01%
-------	-----------------------------	-------

---

It displays the data written by means of the communication address 0x1000.

H0.31	AI1 input voltage (Before correction)	0.01V
H0.32	AI2 input voltage (Before correction)	0.01V
H0.33	AI3 input voltage (Before correction)	0.01V

It displays the AI1 input voltage,AI2 input voltage,AI3 input voltage before correction  
The input current 1mA correspond to 0.5V.

## Chapter 8 Maintenance and Troubleshooting

### 8.1 Routine Repair and Maintenance of the JT580

#### 8.1.1 Routine Maintenance

The influence of the ambient temperature, humidity, dust and vibration will cause the aging

of the devices in the inverter, which may cause potential faults or reduce the service life of the inverter. Therefore, it is necessary to carry out routine and periodic maintenance.

Routine maintenance involves checking:

- Whether the motor sounds abnormally during running
- Whether the motor vibrates excessively during running
- Whether the installation environment of the inverter changes.
- Whether the inverter's cooling fan works normally
- Whether the inverter overheats

Routine cleaning involves:

- Keep the inverter clean all the time.
- Remove the dust, especially metal powder on the surface of the inverter, to prevent the dust from entering the inverter.
- Clear the oil stain on the cooling fan of the inverter.

#### 8.1.2 Periodic Inspection

Perform periodic inspection in places where inspection is difficult.

Periodic inspection involves:

Check and clean the air duct periodically.

Check whether the screws become loose.

Check whether the inverter is corroded.

Check whether the wiring terminals show signs of arcing.

Main circuit insulation test

Prompt: Before measuring the insulating resistance with megameter (500V DC megameter recommended), disconnect the main circuit from the inverter.

Do not use the insulating resistance meter to test the insulation of the control circuit. The high voltage test need not be performed again because it has been completed before delivery.

#### 8.1.3 Replacement of Vulnerable Components

The vulnerable components of the inverter are cooling fan and filter electrolytic capacitor.

Their service life is related to the operating environment and maintenance status.

Generally, the service life is shown as follows:

Fan :2 to 3 years

Electrolytic capacitor: 4 to 5 years

#### 8.1.4 Storage of the inverter

For storage of the inverter, pay attention to the following two aspects:

- 1) Pack the inverter with the original packing box provided by Juditech.
- 2) Long-term storage degrades the electrolytic capacitor. Thus, the inverter must be energized once every 2 years, each time lasting at least 5 hours. The input voltage must be increased slowly to the rated value with the regulator.

### 8.2 Warranty Agreement

1) Free warranty only applies to the inverter itself.

2) Juditech will provide 18-month warranty (starting from the leave-factory date as indicated on the barcode) for the failure or damage under normal use conditions. If the

equipment has been used for over 18 months, reasonable repair expenses will be charged.

3) Reasonable repair expenses will be charged for the damages due to the following causes:

- Improper operation without following the instructions
- Fire, flood or abnormal voltage.
- Using the inverter for non-recommended function

4) The maintenance fee is charged according to Juditech's uniform standard. If there is an agreement, the agreement prevails.

### 8.3 Faults and Solutions

The JT580 provides a total of 24 pieces of fault information and protective functions. After a fault occurs, the inverter implements the protection function, and displays the fault code on the operation panel (if the operation panel is available).

Before contacting Juditech for technical support, you can first determine the fault type, analyze the causes, and perform troubleshooting according to the following tables. If the fault cannot be rectified, contact the agent or Juditech. Err22 is the inverter hardware overcurrent or overvoltage signal. In most situations, hardware overvoltage fault causes Err22.

Fault Name	Display	Possible Causes	Solutions
Overcurrent during acceleration	Err02	1: The output circuit is grounded or short circuited. 2: Motor auto-tuning is not performed. 3: The acceleration time is too short. 4: Manual torque boost or V/F curve is not appropriate. 5: The voltage is too low. 6: The startup operation is performed on the rotating motor. 7: A sudden load is added during acceleration. 8: The inverter model is of too small power class.	1: Eliminate external faults. 2: Perform the motor auto tuning. 3: Increase the acceleration time. 4: Adjust the manual torque boost or V/F curve. 5: Adjust the voltage to normal range. 6: Select rotational speed tracking restart or start the motor after it stops. 7: Remove the added load. 8: Select an inverter of higher power class.
Overcurrent during deceleration	Err03	1: The output circuit is grounded or short circuited. 2: Motor auto-tuning is not performed. 3: The deceleration time is too short.	1: Eliminate external faults. 2: Perform the motor autotuning. 3: Increase the deceleration time. 4: Adjust the voltage to normal range
		4: The voltage is too low. 5: A sudden load is added during deceleration. 6: The braking unit and braking resistor are not installed.	5: Remove the added load. 6: Install the braking unit and braking resistor.

Overcurrent at constant speed	Err04	<p>1: The output circuit is grounded or short circuited.                  2: Motor auto-tuning is not performed.                  3: The voltage is too low.                  4: A sudden load is added during operation.                  5: The inverter model is of too small power class.</p>	<p>1: Eliminate external faults.                  2: Perform the motor autotuning.                  3: Adjust the voltage to normal range.                  4: Remove the added load.                  5: Select an inverter of higher power class.</p>
Overvoltage during acceleration	Err05	<p>1: The input voltage is too high.                  2: An external force drives the motor during acceleration.                  3: The acceleration time is too short.                  4: The braking unit and braking resistor are not installed.</p>	<p>1: Adjust the voltage to normal range.                  2: Cancel the external force or install a braking resistor.                  3: Increase the acceleration time.                  4: Install the braking unit and braking resistor.</p>
Overvoltage during deceleration	Err06	<p>1: The input voltage is too high.                  2: An external force drives the motor during deceleration.                  3: The deceleration time is too short.                  4: The braking unit and braking resistor are not installed</p>	<p>1: Adjust the voltage to normal range.                  2: Cancel the external force or install the braking resistor.                  3: Increase the deceleration time.                  4: Install the braking unit and braking resistor.</p>
Overvoltage at constant speed	Err07	<p>1: The input voltage is too high.                  2: An external force drives the motor during deceleration</p>	<p>1: Adjust the voltage to normal range.                  2: Cancel the external force or install the braking resistor</p>
Control power supply fault	Err08	<p>The input voltage is not within the allowable range.</p>	<p>Adjust the input voltage to the allowable range.</p>
Under voltage	Err09	<p>1: Instantaneous power failure occurs on the input power supply.</p>	<p>1: Reset the fault.                  2: Adjust the voltage to normal range.</p>
		<p>2: The inverter's input voltage is not within the allowable range.                  3: The bus voltage is abnormal.                  4: The rectifier bridge and buffer resistor are faulty.</p>	<p>3: Contact the agent or Juditech.</p>

		5: The drive board is faulty. 6: The main control board is faulty.	
inverter overload	Err10	1: The load is too heavy or locked rotor occurs on the motor. 2: The inverter model is of too small power class	1: Reduce the load and check the motor and mechanical condition. 2: Select an inverter of higher power class.
Motor overload	Err11	1: F9.01 is set improperly. 2: The load is too heavy or locked rotor occurs on the motor. 3: The inverter model is of too small power class	1: Set F9.01 correctly. 2: Reduce the load and check the motor and the mechanical condition. 3: Select an inverter of higher power class.
Power input phase loss	Err12	1: The three-phase power input is abnormal. 2: The drive board is faulty. 3: The lightening board is faulty. 4: The main control board is faulty.	1: Eliminate external faults. 2: Contact the agent or Juditech.
Power output phase loss	Err13	1: The cable connecting the AC drive and the motor is faulty. 2: The inverter's three-phase outputs are unbalanced when the motor is running. 3: The drive board is faulty. 4: The module is faulty.	1: Eliminate external faults. 2: Check whether the motor three-phase winding is normal. 3: Contact the agent or Juditech.
Module overheat	Err14	1: The ambient temperature is too high. 2: The air filter is blocked. 3: The fan is damaged. 4: The thermally sensitive resistor of the module is damaged.	1: Lower the ambient temperature. 2: Clean the air filter. 3: Replace the damaged fan. 4: Replace the damaged thermally sensitive resistor. 5: Replace the inverter module.
		5: The inverter module is damaged.	
External equipment fault	Err15	1: External fault signal is input via X. 2: External fault signal is input via virtual I/O.	Reset the operation.
Communicati	Err16	1: The host computer is in	1: Check the cabling of host



on fault		<p>abnormal state.                  2: The communication cable is faulty.                  3: F0.28 is set improperly.                  4: The communication parameters in group FD are set improperly.</p>	<p>computer.                  2: Check the communication cabling.                  3: Set F0-28 correctly.                  4: Set the communication parameters properly.</p>
Contactor fault	Err17	<p>1: The drive board and power supply are faulty.                  2: The contactor is faulty.</p>	<p>1: Replace the faulty drive board or power supply board.                  2: Replace the faulty contactor.</p>
Current detection fault	Err18	<p>1: The HALL device is faulty.                  2: The drive board is faulty</p>	<p>1: Replace the faulty HALL device.                  2: Replace the faulty drive board.</p>
Motor auto-tuning fault	Err19	<p>1: The motor parameters are not set according to the nameplate.                  2: The motor auto-tuning times out</p>	<p>1: Set the motor parameters according to the nameplate properly.                  2: Check the cable connecting the inverter and the motor.</p>
Encoder fault	Err20	<p>1: The encoder type is incorrect.                  2: The cable connection of the encoder is incorrect.                  3: The encoder is damaged.                  4: The PG card is faulty</p>	<p>1: Set the encoder type correctly based on the actual situation.                  2: Eliminate external faults.                  3: Replace the damaged encoder.                  4: Replace the faulty PG card.</p>
EEPROM readwrite fault	Err21	<p>The EEPROM chip is damaged</p>	<p>Replace the main control board.</p>
inverter hardware fault	Err22	<p>1: Overvoltage exists.                  2: Overcurrent exists.</p>	<p>1: Handle based on overvoltage.                  2: Handle based on overcurrent.</p>
Short circuit to ground	Err23	<p>The motor is short circuited to the ground.</p>	<p>Replace the cable or motor</p>
User-defined fault 1	Err27	<p>The user-defined fault 1 signal is input via X.</p>	<p>Reset the operation</p>
User-defined fault 2	Err28	<p>The user-defined fault 2 signal is input via X.</p>	<p>Reset the operation</p>
Accumulative power-on time reached	Err29	<p>The accumulative power-on time reaches the setting value (F4.16)</p>	<p>Clear the record through the parameter initialization function.</p>
Load becoming 0	Err30	<p>The inverter running current is</p>	<p>Check that the load is disconnected or the setting of</p>

		lower than F9.64	F9.64 and F9.65 is correct.
PID feedback lost during running	Err31	The PID feedback is lower than the setting of FA.26.	Check the PID feedback signal or set FA.26 to a proper value.
Pulse-by-pulse current limit fault	Err40	1: The load is too heavy or locked rotor occurs on the motor. 2: The inverter model is of too small power class	1:Reduce the load and check the motor and mechanical condition. 2: Select an inverter of higher power class.
Too large speed deviation	Err42	1: The encoder parameters are set incorrectly. 2: The motor auto-tuning is not performed. 3: F9-69 and F9-70 are set incorrectly.	1:Set the encoder parameters properly. 2: Perform the motor autotuning. 3: Set F9.69 and F9.70 correctly based on the actual situation.
Motor over-speed	Err43	1: The encoder parameters are set incorrectly. 2: The motor auto-tuning is not performed. 3: F9.67 and F9.68 are set incorrectly	1:Set the encoder parameters properly. 2: Perform the motor auto tuning. 3: Set F9.67 and F9.68 correctly based on the actual situation.

### 8.4 Common Faults and Solutions

SN	Fault	Possible Causes	Solutions
1	There is no display at power-on.	1: There is no power supply to the inverter or the power input to the inverter is too low. 2: The power supply of the switch on the drive board of the inverter is faulty. 3: The rectifier bridge is damaged. 4: The control board or the operation panel is faulty. 5: The cable connecting the control board and the drive board and the operation panel breaks.	1: Check the power supply. 2: Check the bus voltage. 3:Re-connect the 8-core and 28-core cables. 4: Contact the agent or Juditech for technical support.
2	Garbled is displayed at power-on	1: The cable between the drive board and the control board is in poor contact. 2: Related components on the control board are damaged. 3: The motor or the motor cable is short circuited to the ground. 4: The HALL device is faulty. 5: The power input to the inverter is too low.	1:Re-connect the 8-core and 28-core cables. 2:Contact the agent or Juditech for technical support.

3	“Err23” is displayed at power-on.	<ol style="list-style-type: none"> <li>1: The motor or the motor output cable is short-circuited to the ground.</li> <li>2: The inverter is damaged.</li> </ol>	<ol style="list-style-type: none"> <li>1: Measure the insulation of the motor and the output cable with a megger.</li> <li>2: Contact the agent or Juditech for technical support.</li> </ol>
4	Err14 (module overheat) fault is reported frequently	<ol style="list-style-type: none"> <li>1: The setting of carrier frequency is too high.</li> <li>2: The cooling fan is damaged, or the air filter is blocked.</li> <li>3: Components inside the inverter are damaged (thermal coupler or others).</li> </ol>	<ol style="list-style-type: none"> <li>1: Reduce the carrier frequency (F0.15).</li> <li>2: Replace the fan and clean the air filter.</li> <li>3: Contact the agent or Juditech for technical support.</li> </ol>
5	The motor does not rotate after the inverter runs.	<ol style="list-style-type: none"> <li>1: Check the motor and the motor cables.</li> <li>2: The inverter parameters are set improperly (motor parameters).</li> <li>3: The cable between the drive board and the control board is in poor contact.</li> <li>4: The drive board is faulty.</li> </ol>	<ol style="list-style-type: none"> <li>1: Ensure the cable between the inverter and the motor is normal.</li> <li>2: Replace the motor or clear mechanical faults.</li> <li>3: Check and re-set motor parameters</li> </ol>
6	The X terminals are disabled.	<ol style="list-style-type: none"> <li>1: The parameters are set incorrectly.</li> <li>2: The external signal is incorrect.</li> <li>3: The jumper bar across OP and +24 V becomes loose.</li> <li>4: The control board is faulty.</li> </ol>	<ol style="list-style-type: none"> <li>1: Check and reset the parameters in group F4.</li> <li>2: Re-connect the external signal cables.</li> <li>3: Re-confirm the jumper bar across OP and +24 V.</li> <li>4: Contact the agent or Juditech for technical support.</li> </ol>
7	The motor speed is always low in CLVC mode	<ol style="list-style-type: none"> <li>1: The encoder is faulty.</li> <li>2: The encoder cable is connected incorrectly or in poor contact.</li> <li>3: The PG card is faulty.</li> <li>4: The drive board is faulty.</li> </ol>	<ol style="list-style-type: none"> <li>1: Replace the encoder and ensure the cabling is proper.</li> <li>2: Replace the PG card.</li> <li>3: Contact the agent or Juditech for technical support.</li> </ol>
8	The inverter reports overcurrent and overvoltage frequently	<ol style="list-style-type: none"> <li>1: The motor parameters are set improperly.</li> <li>2: The acceleration/deceleration time is improper.</li> <li>3: The load fluctuates</li> </ol>	<ol style="list-style-type: none"> <li>1: Re-set motor parameters or re-perform the motor autotuning.</li> <li>2: Set proper acceleration/ deceleration time.</li> <li>3: Contact the agent or Juditech for technical support.</li> </ol>
9	Err17 is reported upon power-on or running	The soft startup contactor is not picked up.	<ol style="list-style-type: none"> <li>1: Check whether the contactor cable is loose.</li> <li>2: Check whether the contactor is faulty.</li> <li>3: Check whether 24 V power supply of the contactor is faulty.</li> <li>4: Contact the agent or Juditech for technical support</li> </ol>
10	“8.8.8.8.”is displayed upon power-on	Related component on the control board is damaged.	Replace the control board

